

Money and Labor saving Elevation Rings

Froet Industries LLC has now developed a cost effective alternative to extensions and drain pans. It is our Elevation Rings for our 3" thru 6" drains. This new accessory will eliminate the need for the drain pan and an extension in some cases. The unique design of the elevation ring assures the elimination of ponding around the roof drain. It accomplishes this by providing a fixed height of elevation so that the drain is installed with the top of the drain ring surface level with the common insulation thickness used in the roofing industry 1 1/2" and 2". Another advantage is most of the roofing insulation used has a minimum thickness requirement of 1 1/2" for use over the common ribbed metal decks used today. This means that a drain pan is not needed.

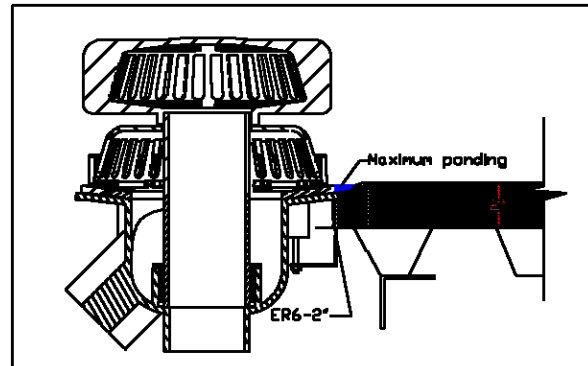

With the fixed height of the ER- Elevation ring, it will assure the drain is installed at the correct height to prevent ponding. Most everyone thinks the top of the sump flange is the proper height to set the drain by, but it is not. Even the thickness of the drain ring can cause a pond that becomes a magnet for debris which in turn, begins the never ending cycle of slowly plugging the drain strainer. This is why the ER is designed to set the drain so that the start of the free area is at insulation level. Some drains in the industry do not start to have free area until 7/8" above the sump flange. It is imperative to set the drain to the correct elevation so no ponding will occur and will provide a low maintenance roof drain installation.