

Table of Contents

	<u>Page</u>		
Froet Drain ®	2		
Installation instructions	3-5	100C6	29
100C2LP-OFS	6	100C6-FR	30
100C2-OFS	7	100C6LP	31
3" Overall Dimensions	8	100C6LP-OFS	32
100C3	9	100C6LP-FR-DC	33
100C3-OFS	10	100C6-DEX-4-FR	34
100C3LP-DEX-2	11	100C6-CFW	35
100C3LP-OFS-DEX2	12	100C6-VP	36
100C3LP-OFS-DEX-4	13	100C8	37
4" Overall Dimensions	14	100C8LP	38
100C4-OFS	15	100C8-OFS	39
100C4	16	100C8LP-OFS	40
100C4LP-90	17	100C8LP-OFS-DC	41
100C4LP-90-OFSL	18	Alternate details	
100C4-DMP	19	Green roof/ Patio	42
100C4-DEX-2-DC	20	Planter	43
100C4-DEX-4-IG	21	200C3 Standard drain	44
100C4LP-DEX-6-FR-OFS	22	200C4 Standard drain	45
100C4-CFW	23	200C5 Standard drain	46
100C4-VP	24	200C6 Standard drain	47
5" Overall Dimensions	25	Product Information & Design Criteria	48-51
100C5LP-OFS	26	General Terms and Conditions	52-53
6" Overall Dimensions	27		
100C6-OFS with Dimensions	28		

Disclaimer:

Seller warrants that the Froet Drain® roof drain will be of the kind and quality described in the order and product literature and will be free of defects in workmanship or material. However, Seller does not warrant the application and use of the drain based upon the structural design and installation on a particular project. Careful consideration must be placed on the actual design of the structure when determining the burden of the overflow water.

08/2011

Froet Drain® Roof Drain

The patented Froet Drain® is an innovative drain product created to solve the dual drain requirement for overflow protection. With both functions designed into one drain it greatly simplifies the roof drainage design. Our drain is designed in such a way that it can more efficiently remove rainwater from roofs than standard drains. The design process started with the goal to design the most advanced roof drainage system. We have strived to create a product to satisfy the specific needs and requirements of both the architect and engineers in one unit. Our design incorporates the following features:

- ◆ Superior powder coated finish
- ◆ Patented sump design
- ◆ Corrosion-resistant fasteners (pre-applied anti-seize to drain ring bolts)
- ◆ Increased clamping ring surface
- ◆ Taller gravel retention
- ◆ Aesthetically pleasing design

Froet Drain® Roof Drain Part Description

Standard Supplies a 5" high primary strainer with a 6" high overflow inlet

- LP** **Low Profile**-This option supplies a 3" high primary strainer with a 4" high overflow inlet
- DC** **Deck Clamp**- A round L shaped clamp to hold the drain body in place for the 3,4,5, & 6 inch drains. The deck clamp for the 8 inch drain is a two piece straight L shaped clamp.
- DEX** **Drain Extension**-Is offered in heights of 2",4"& 6". Incorporated in this option will be the correct size over flow pipe and sealing gasket. The drain extensions can be installed in multiple configurations to adapt to any need (reference pg. 11).
- DP** **Drain Pan**-A flat 30" X 30" X 14 gauge plate for the 3,4,5 & 6 inch drains to mount the drain to when required (Finishing ring supplied with this drain pan) The 8 inch drain pan is 35 1/2" X 35 1/2" X 1/8" and does not require a FR
- SP** **Sump Pan**-1 1/2" deep 29" X 33" ,14 gauge galvanized steel sump pan 3' wide flange, 23" X 27" sump area (requires field cutting to install drain) Please note: This pan is not large enough for the 8" drain.
- DMP** **Deck Mounting Plate**-A flat 30"X 30" X 14 Gauge plate that allows the drain to be bolted directly to it which eliminates the need for the deck clamp. This part can only be used if there is a **minimum of 2 1/2" of insulation on the roof deck**. The 8 inch deck mounting plate is 35 1/2" X 35 1/2" X 1/8" **and requires minimum of 3" of insulation**.
- FR** **Finishing Ring**-A recessed ring to allow the drain body to be installed in a flush configuration, either directly to the deck or into the drain pan. Offered for the 3,4,5 & 6 inch drains only.
- OFS** **Overflow Strainer**- Debris strainer to be used on the overflow pipe. This part also incorporates a set screw to provide vandal proofing.
- OFSL** **Overflow Strainer Low Profile- 3" and 4" drains only** Debris strainer for overflow pipe that is smaller and does not flow as well as the standard OFS for use in planters or patio applications.
- VP** **Vent Pipe**-12" extension above the primary drain strainer is to be used as a plumbing vent pipe when the overflow drain is not needed.
- CFW** **Control Flow Weir**-can be configured on the jobsite for the required amount of flow. The weir is produced with one open weir, additional weirs can be opened with a metal cutting saw to provide the design flow. The weir can also be removed from the drain without breaking the roofing seal to facilitate cleaning of the drain.
- IG** **IRMA Roof Guard**-Perforated stainless steel guard used with IRMA roofing systems, supplied in same elevation as overflow height.
- ER** **Elevation Rings**-A elevated base to elevate the 3",4", 5",or 6" drain for use with 1.5" or 2" insulation so that the top of the drain ring is level with the insulation to prevent ponding can be used with or without the drain pans.
- VPS** **Vandal Protection**-for the standard primary drains

Ordering definition

Style Breakdown: 100C4

100	Series	C	Cast Iron	4	Outlet size
<u>100C6</u>	<u>Profile</u>	<u>Extensions</u>	<u>Additional options</u>		
100C6		Dex-2	DC		
100C4	LP	Dex-4-Dex-2	FR-DC-OFS		

The above product numbers designates the following:

6" Bi-functional roof drain standard profile strainer, 2" extension, deck clamp

4" Bi-functional roof drain with low profile strainer, 4" and 2" extension, finishing ring, deck clamp and overflow strainer.

Installation Information

The installation of the Froet Drain® roof drain installs much the same as a standard roof drain. All of the accessories are like that of a standard drain. The following are useful points to aid in installation of our drain.

Keep in mind the orientation of the primary outlet so it is pointed in the easiest direction for the piping. There is 3.5" from bottom of sump flange to the top of primary outlet on the 4" drain this will allow for the drain to be elevated 1-1/2" if you are using it with 1-1/2" metal deck. Or to clear larger structural supports around underside of the drain sump area. In some cases the primary outlet may need to be orientated to the corner of the structural framing to provide clearance of the primary outlet plumbing.

The drain can be totally assembled and clamped to drain pan and then installed in deck opening if desired.

If using extensions and supporting the drain from that extension, install finishing ring on extension before installation to sump.

If you are using extensions to add height to the drain for thick insulation and are supporting drain from the sump you will not need finishing ring for the extension.

- Install gasket between sump and extension and tighten evenly.
- Outlet in bottom of sump is the overflow outlet.
- Outlet in side of sump is the primary outlet.
- The flat drain pan includes the finishing ring when ordered.
- The finishing ring is recessed to allow the drain to be installed flush with the flat drain pan.
- The sumped pan needs to be field cut for installation of drain.
- The under deck clamp is C shaped to clear the primary outlet.
- Donut seal must be installed at bottom of sump and overflow riser pipe (supplied) for proper operation of drain.
- Drain needs to be installed per all local and state codes.
- Protect drain from damage and from construction debris entering drainage system.
- Inspect drain at end of construction process to verify drains remain unobstructed.

There are pictures of installed projects on our website on the news and update page and drawings of different drain configurations and installations (example page 4) on our spec & drawings page to aid in installation. www.froetindustries.com

There are nine installation options for the drain and are as follows:

- ◆ Poured in place (concrete deck)
- ◆ Set directly on deck 13" hole for 3" & 4" drain, 16" hole for 5" & 6" drain and 22 3/4" for 8" drain (any deck excluding thick concrete)
- ◆ Set flush in finishing ring and finishing ring set on deck 15" hole for 3" & 4" & 19" hole for 5" & 6" (any deck)
- ◆ Set flush in finishing ring and deck plate in 27" X 27" hole in deck for 3", 4", 5" & 6" (any deck)
- ◆ Set on deck plate in 31 1/2" X 31 1/2" hole in deck for 8" (any deck)
- ◆ Set in sumped pan 27" X 24" hole in deck 3", 4", 5" & 6" (any Deck)
- ◆ Bolted to DMP-3/4 or 5/6 pan 27" X 27" hole in deck (any deck) eliminates deck clamp for 3", 4", 5" & 6"
Must have a minimum of 2 1/2" of insulation on deck at drain
- ◆ Set on Elevation Ring when roofing system has 1.5' or 2" insulation at drain with 3", 4", 5" & 6" (any Deck)
- ◆ Bolted to DMP-8 pan 31 1/2" X 31 1/2" hole in deck (any deck excluding thick concrete)
eliminates deck clamp for 8" **Must have a minimum of 3" of insulation on deck at drain**

PLEASE NOTE:

- A. All DP's, DMP's and SP's must be fastened securely to deck or structural components to prevent fall hazard.
- B. Deck must be properly supported to receive roof drain
- C. The overflow system will be sized at a minimum, equal to the primary system.
- D. Coordinated with the structural design to withstand the operating load of the primary and/or secondary drainage systems.

Froet Drain Strainer Free Area					
Drain size	IPC free area requirement in. ²	ASME A112.6.4-2003 free area in. ²	Froet Drain 3" high primary strainer free area in. ²	Froet Drain 5" high primary strainer free area in. ²	Froet Drain secondary strainer free area in. ²
2"	4.71	18	30	48	73
3"	10.59	25	62	90	105
4"	18.84	36	62	90	105
5"	28.87	50	95	127	146
6"	43.31	70	95	127	146
8"	75.36	NA	163	203	200

E. This drain outlet is not intended to be connected to the plumbing vent.

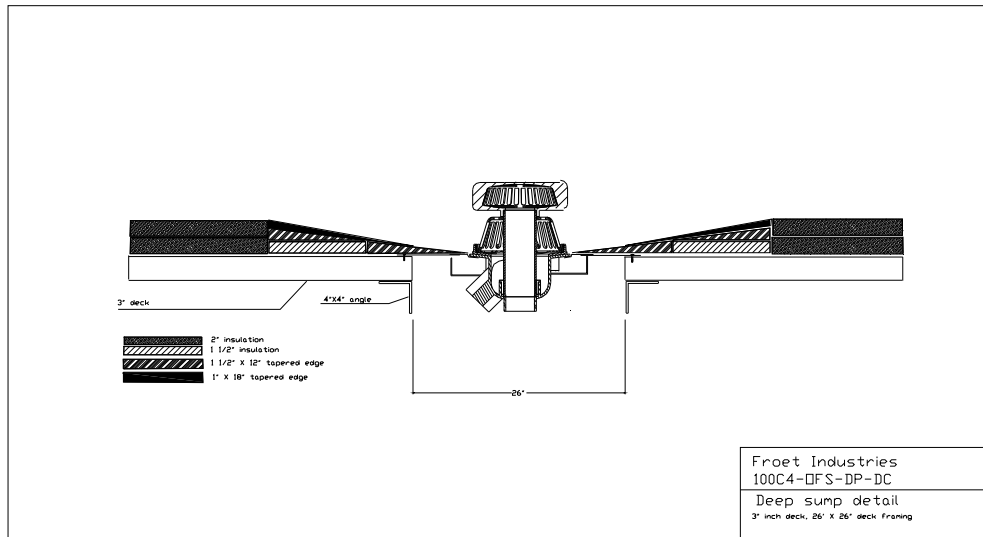

Froet Drain[®] Roof Drain's Innovative design

The primary outlet is attached to the storm sewer or to an outlet at grade. The overflow connection is attached to a relieve area outside of the building separate from the primary system. Check your local building code for proper attachments.

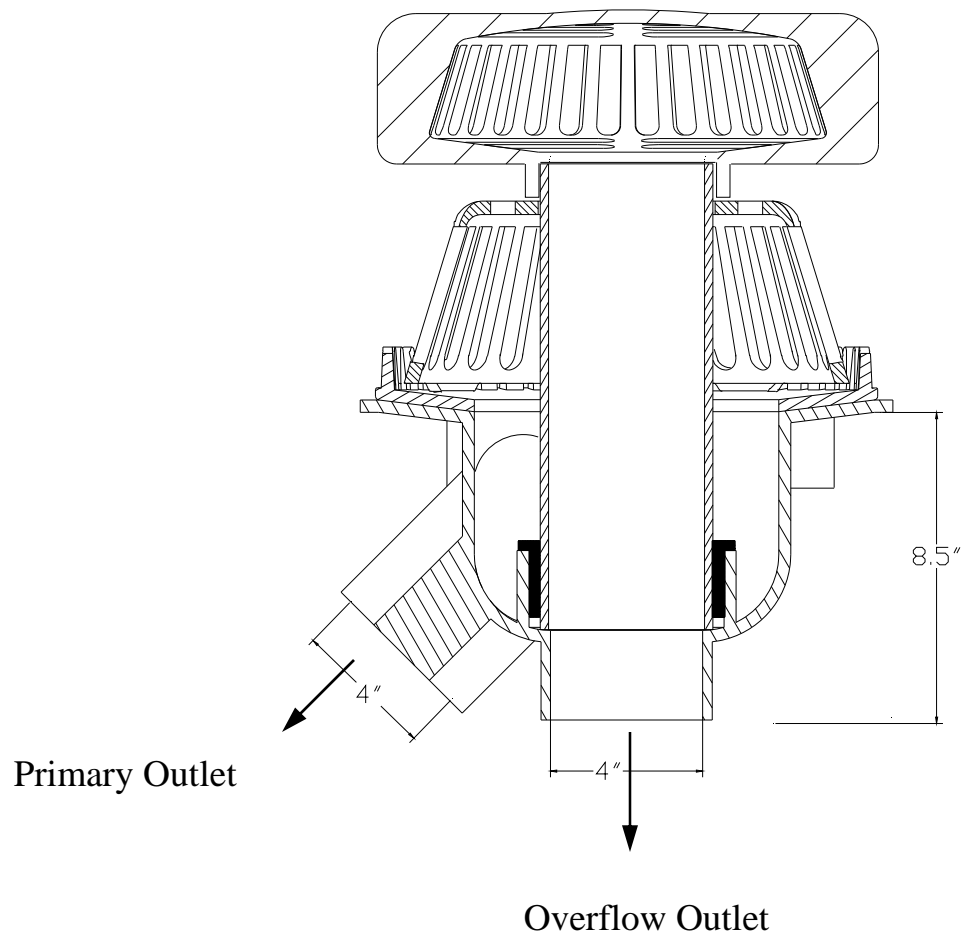

Froet Drain® Bi-Functional Roof Drain 100C2

Patent #US6594966

100C2LP-OFS

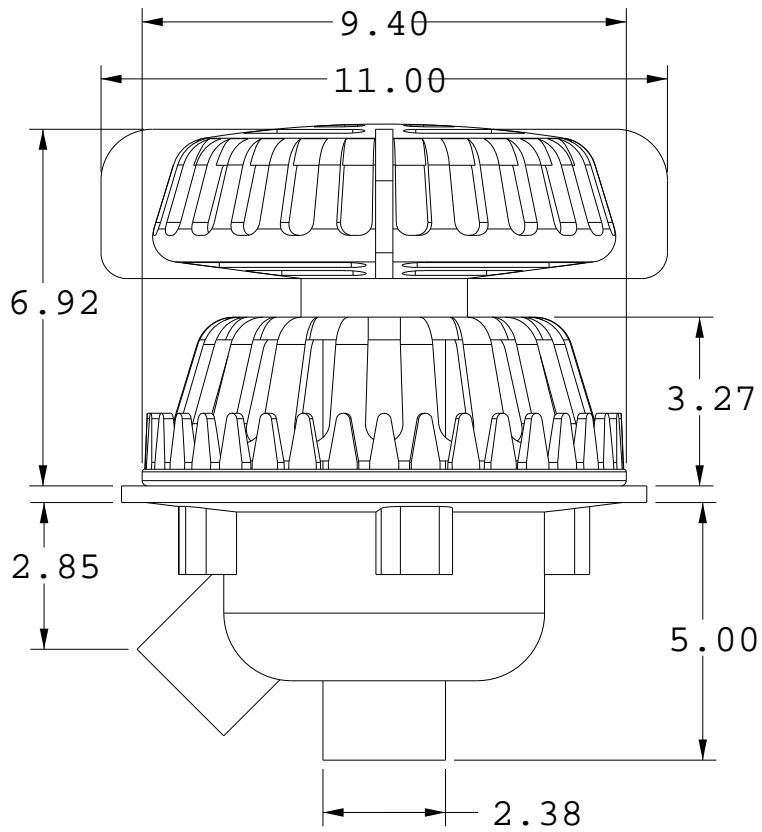

OFS	Overflow Strainer	DP	Drain Pan
DC	Deck Clamp	DMP	Deck Mounting Plate

Specifications subject to change without notice

Froet Drain® Bi-Functional Roof Drain 100C2

Patent #US6594966

100C2-OFS

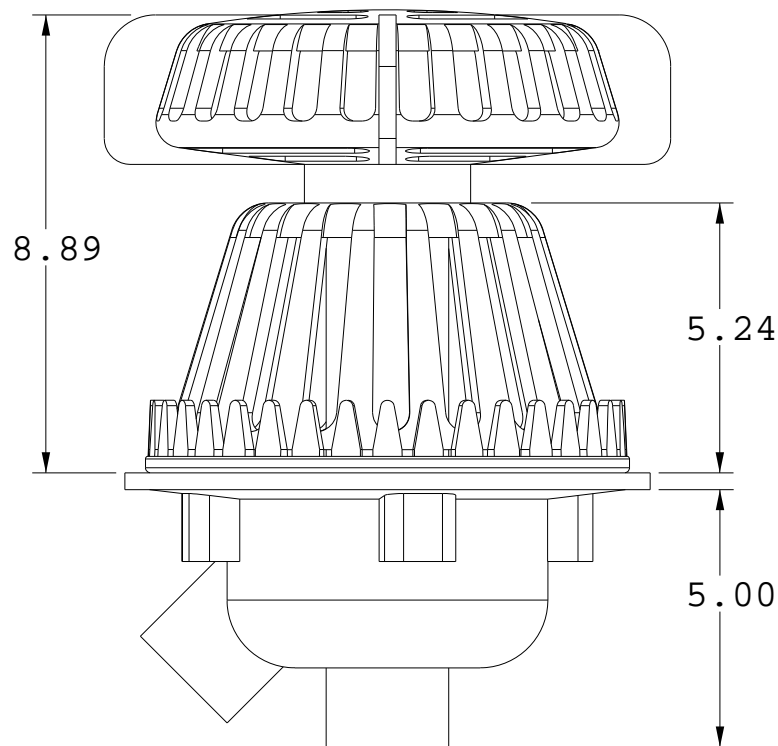

OFS	Overflow Strainer	DP	Drain Pan
DC	Deck Clamp	DMP	Deck Mounting Plate



Specifications subject to change without notice

Froet Drain® Bi-Functional Roof Drain 100C3

Patent #US6594966

3" Overall Dimensions

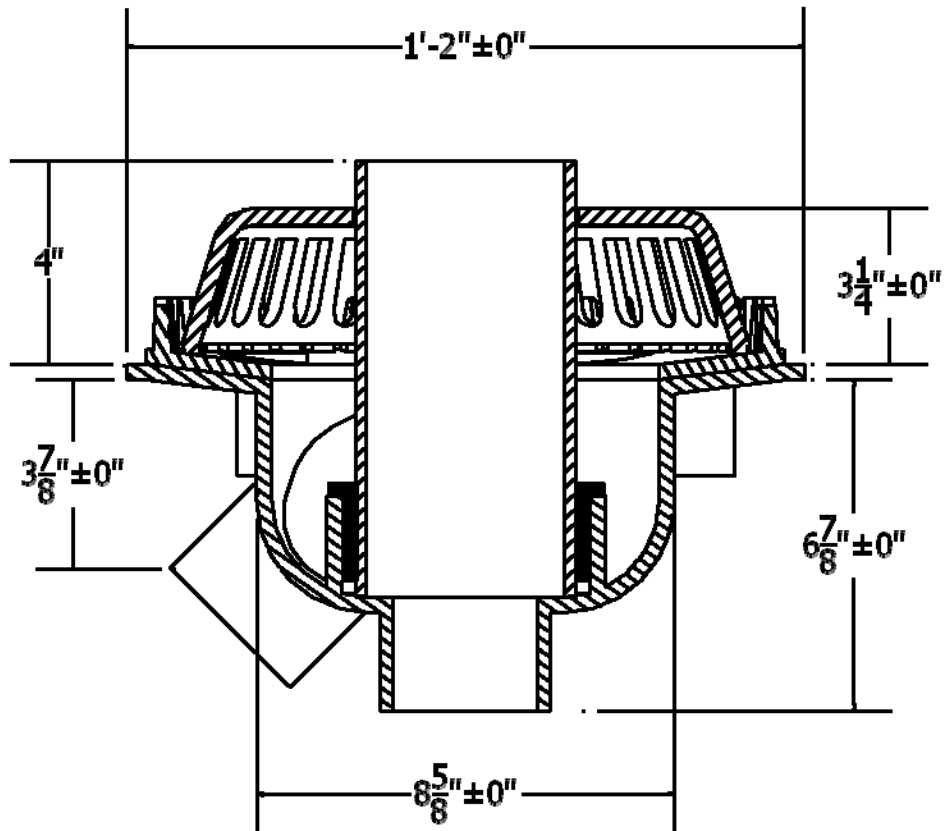

Specifications subject to change without notice

Froet Drain® Bi-Functional Roof Drain 100C3

Patent #US6594966

100C3

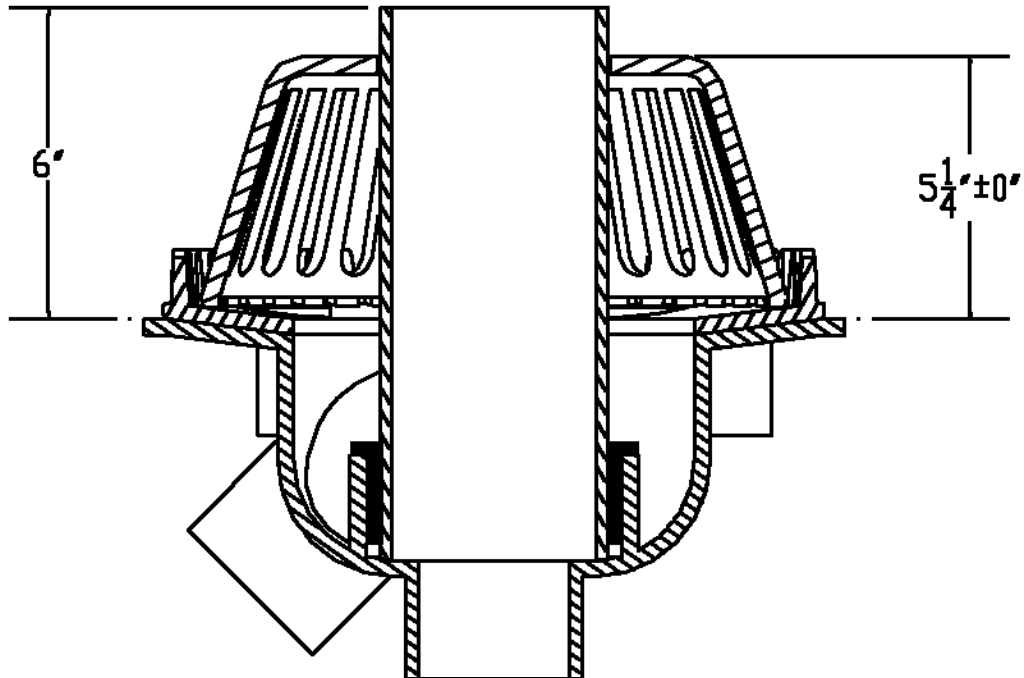

LP	Low Profile	FR	Finishing Ring
DC	Deck Clamp	VP	Vent Pipe
DEX-2	2" Ring Extension	IG	IRMA Roof Guard
DEX-4	4" Ring Extension	SP	Sump Drain Pan
DEX-6	6" Ring Extension	OFSL	Overflow Strainer Low Profile
DP	Drain Pan	DMP	Deck Mounting Plate
OFS	Overflow Strainer	CFW	Control Flow Weir
ER 1.5	Elevation Ring for 1-1/2" Insulation	ER 2	Elevation Ring for 2" Insulation

Specifications subject to change without notice

Froet Drain® Bi-Functional Roof Drain 100C3

Patent #US6594966

100C3-OFS

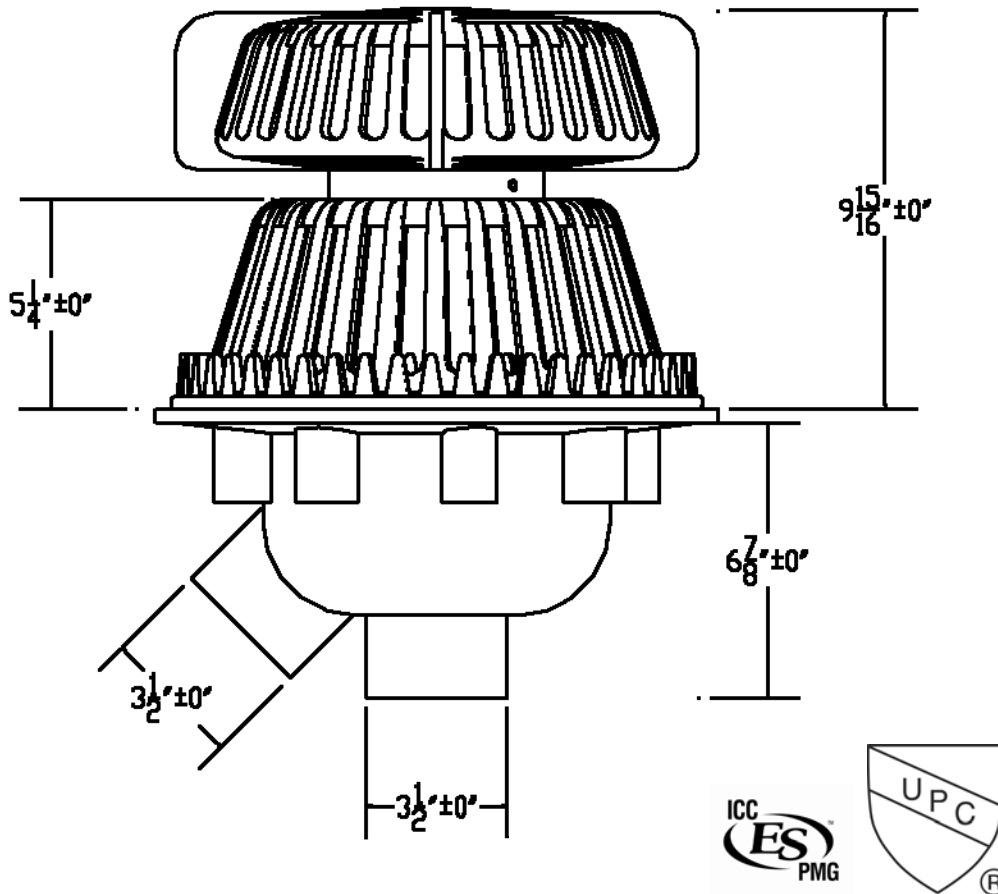

LP	Low Profile	FR	Finishing Ring
DC	Deck Clamp	VP	Vent Pipe
DEX-2	2" Ring Extension	IG	IRMA Roof Guard
DEX-4	4" Ring Extension	SP	Sump Drain Pan
DEX-6	6" Ring Extension	OFSL	Overflow Strainer Low Profile
DP	Drain Pan	DMP	Deck Mounting Plate
OFS	Overflow Strainer	CFW	Control Flow Weir
ER 1.5	Elevation Ring for 1-1/2" Insulation	ER 2	Elevation Ring for 2" Insulation

Specifications subject to change without notice

Froet Drain® Bi-Functional Roof Drain 100C3

Patent #US6594966

100C3LP-DEX-2

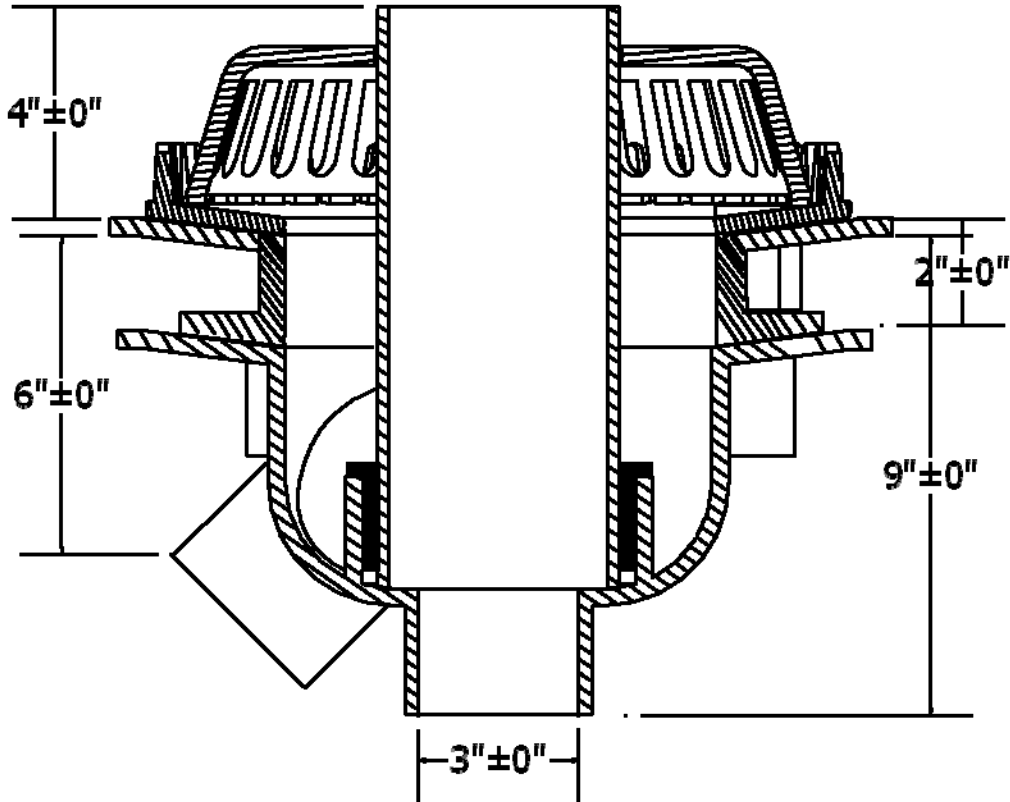

LP	Low Profile	FR	Finishing Ring
DC	Deck Clamp	VP	Vent Pipe
DEX-2	2" Ring Extension	IG	IRMA Roof Guard
DEX-4	4" Ring Extension	SP	Sump Drain Pan
DEX-6	6" Ring Extension	OFSL	Overflow Strainer Low Profile
DP	Drain Pan	DMP	Deck Mounting Plate
OFS	Overflow Strainer	CFW	Control Flow Weir
ER 1.5	Elevation Ring for 1-1/2" Insulation	ER 2	Elevation Ring for 2" Insulation

Specifications subject to change without notice

Froet Drain® Bi-Functional Roof Drain 100C3

Patent #US6594966

100C3LP-OFS-DEX-2

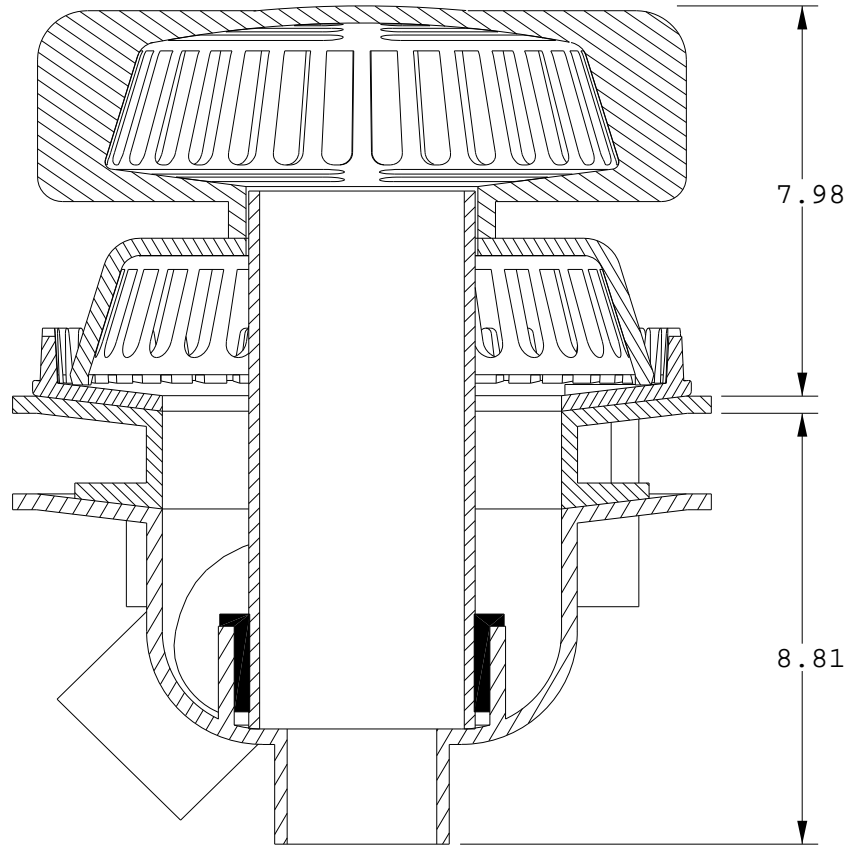

LP	Low Profile	FR	Finishing Ring
DC	Deck Clamp	VP	Vent Pipe
DEX-2	2" Ring Extension	IG	IRMA Roof Guard
DEX-4	4" Ring Extension	SP	Sump Drain Pan
DEX-6	6" Ring Extension	OFSL	Overflow Strainer Low Profile
DP	Drain Pan	DMP	Deck Mounting Plate
OFS	Overflow Strainer	CFW	Control Flow Weir
ER 1.5	Elevation Ring for 1-1/2" Insulation	ER 2	Elevation Ring for 2" Insulation

Specifications subject to change without notice

Froet Drain® Bi-Functional Roof Drain 100C3

Patent #US6594966

100C3LP-OFS-DEX-4

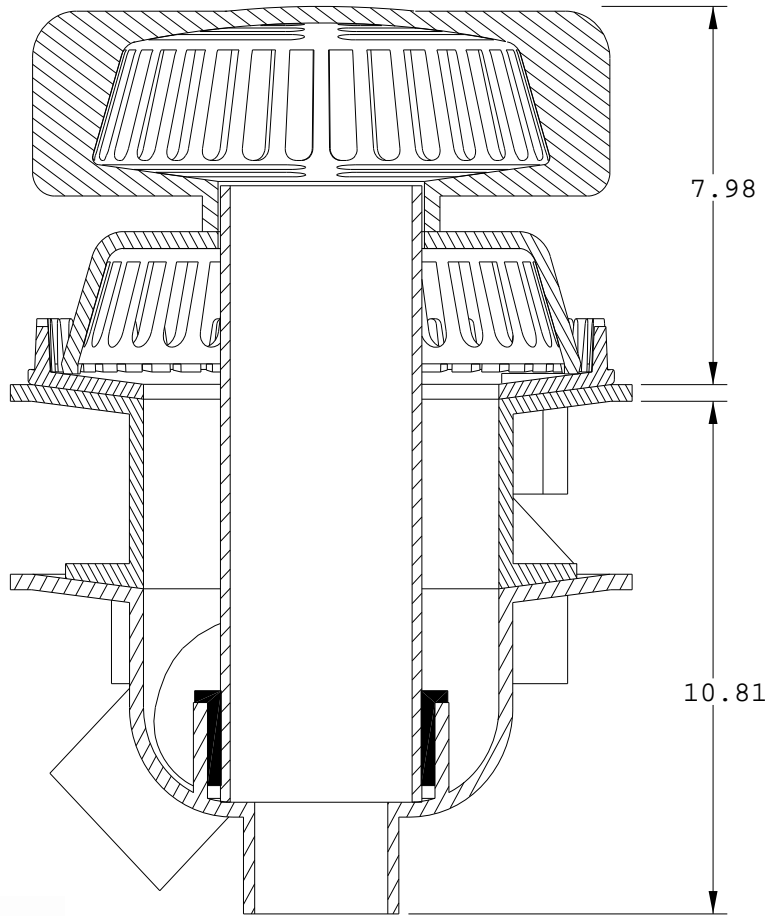

LP	Low Profile	FR	Finishing Ring
DC	Deck Clamp	VP	Vent Pipe
DEX-2	2" Ring Extension	IG	IRMA Roof Guard
DEX-4	4" Ring Extension	SP	Sump Drain Pan
DEX-6	6" Ring Extension	OFSL	Overflow Strainer Low Profile
DP	Drain Pan	DMP	Deck Mounting Plate
OFS	Overflow Strainer	CFW	Control Flow Weir
ER 1.5	Elevation Ring for 1-1/2" Insulation	ER 2	Elevation Ring for 2" Insulation

Specifications subject to change without notice

Froet Drain® Bi-Functional Roof Drain 100C4LP

Patent #US6594966

100C4LP Overall Dimensions

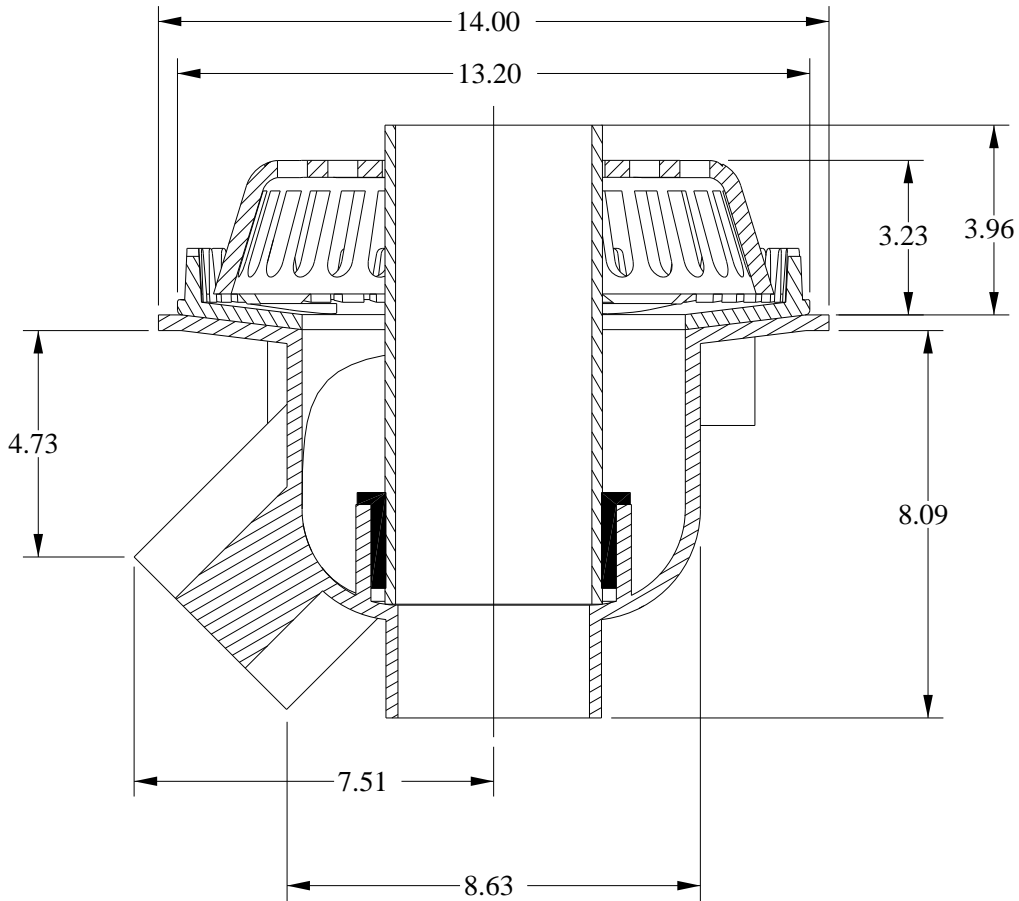

LP	Low Profile	FR	Finishing Ring
DC	Deck Clamp	VP	Vent Pipe
DEX-2	2" Ring Extension	IG	IRMA Roof Guard
DEX-4	4" Ring Extension	SP	Sump Drain Pan
DEX-6	6" Ring Extension	OFSL	Overflow Strainer Low Profile
DP	Drain Pan	DMP	Deck Mounting Plate
OFS	Overflow Strainer	CFW	Control Flow Weir
ER 1.5	Elevation Ring for 1-1/2" Insulation	ER 2	Elevation Ring for 2" Insulation

Specifications subject to change without notice

Froet Drain® Bi-Functional Roof Drain 100C4

Patent #US6594966

100C4-OFS

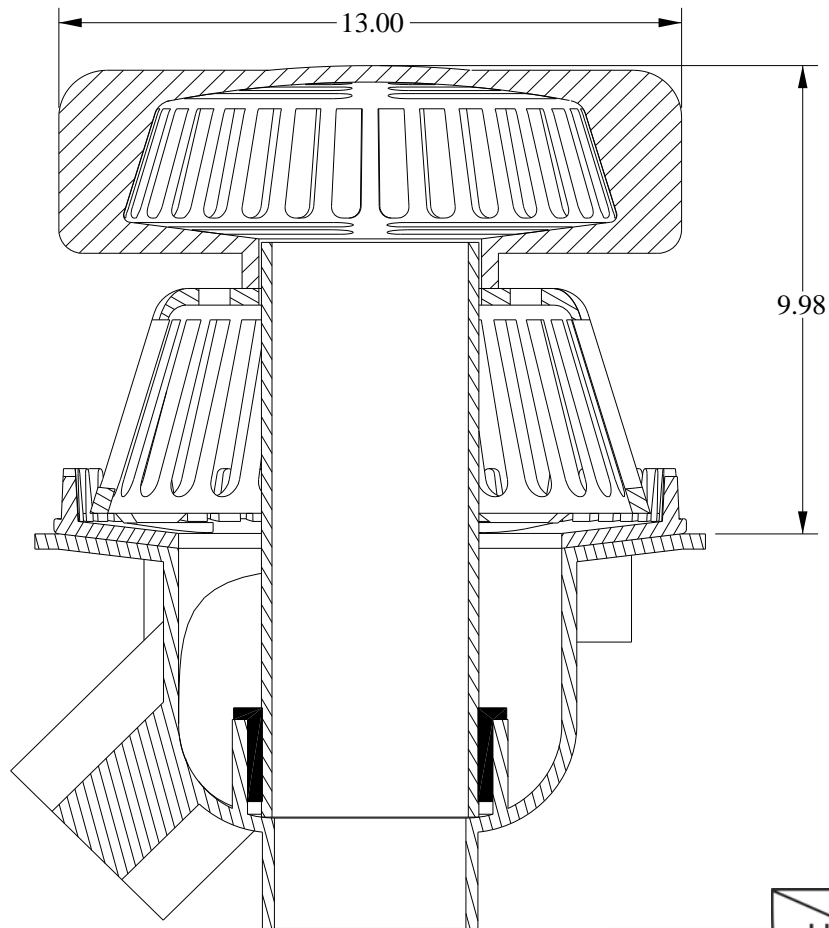

LP	Low Profile	FR	Finishing Ring
DC	Deck Clamp	VP	Vent Pipe
DEX-2	2" Ring Extension	IG	IRMA Roof Guard
DEX-4	4" Ring Extension	SP	Sump Drain Pan
DEX-6	6" Ring Extension	OFSL	Overflow Strainer Low Profile
DP	Drain Pan	DMP	Deck Mounting Plate
OFS	Overflow Strainer	CFW	Control Flow Weir
ER 1.5	Elevation Ring for 1-1/2" Insulation	ER 2	Elevation Ring for 2" Insulation

Specifications subject to change without notice

Froet Drain® Bi-Functional Roof Drain 100C4

Patent #US6594966

100C4

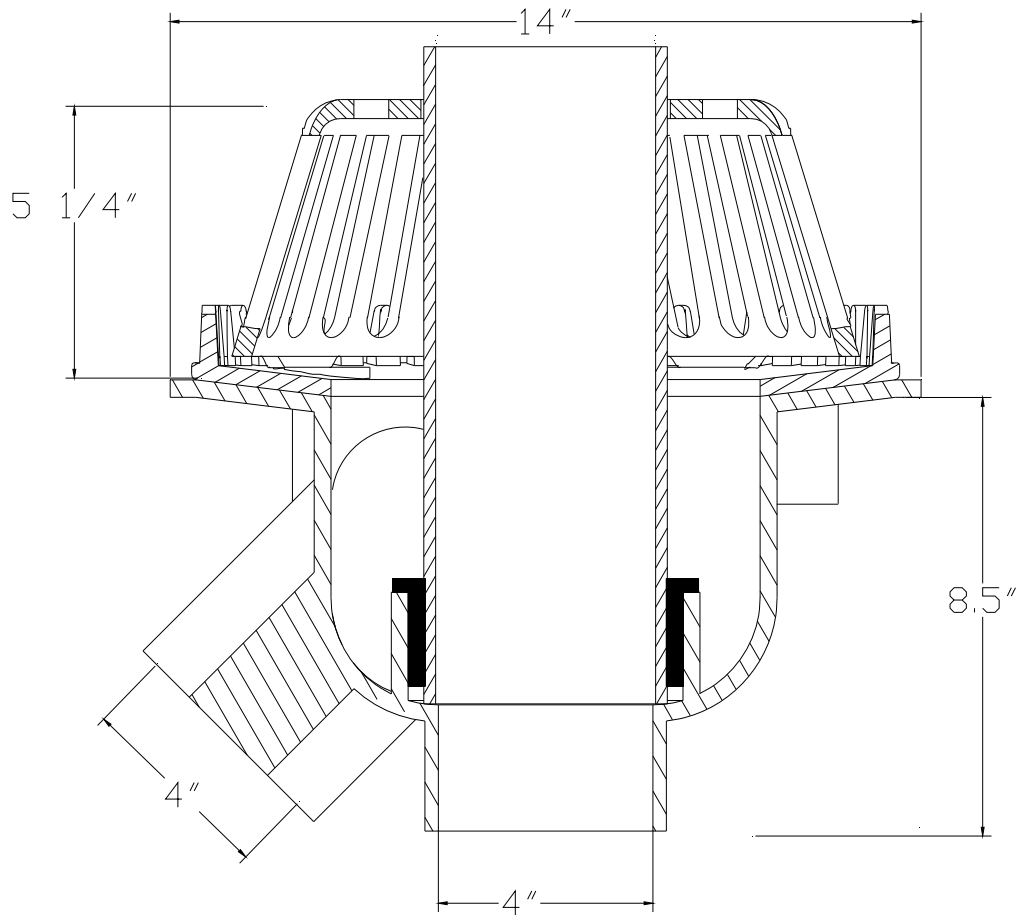

LP	Low Profile	FR	Finishing Ring
DC	Deck Clamp	VP	Vent Pipe
DEX-2	2" Ring Extension	IG	IRMA Roof Guard
DEX-4	4" Ring Extension	SP	Sump Drain Pan
DEX-6	6" Ring Extension	OFSL	Overflow Strainer Low Profile
DP	Drain Pan	DMP	Deck Mounting Plate
OFS	Overflow Strainer	CFW	Control Flow Weir
ER 1.5	Elevation Ring for 1-1/2" Insulation	ER 2	Elevation Ring for 2" Insulation

Specifications subject to change without notice

Froet Drain® Bi-Functional Roof Drain 100C4-90

Patent #US6594966

100C4LP-90

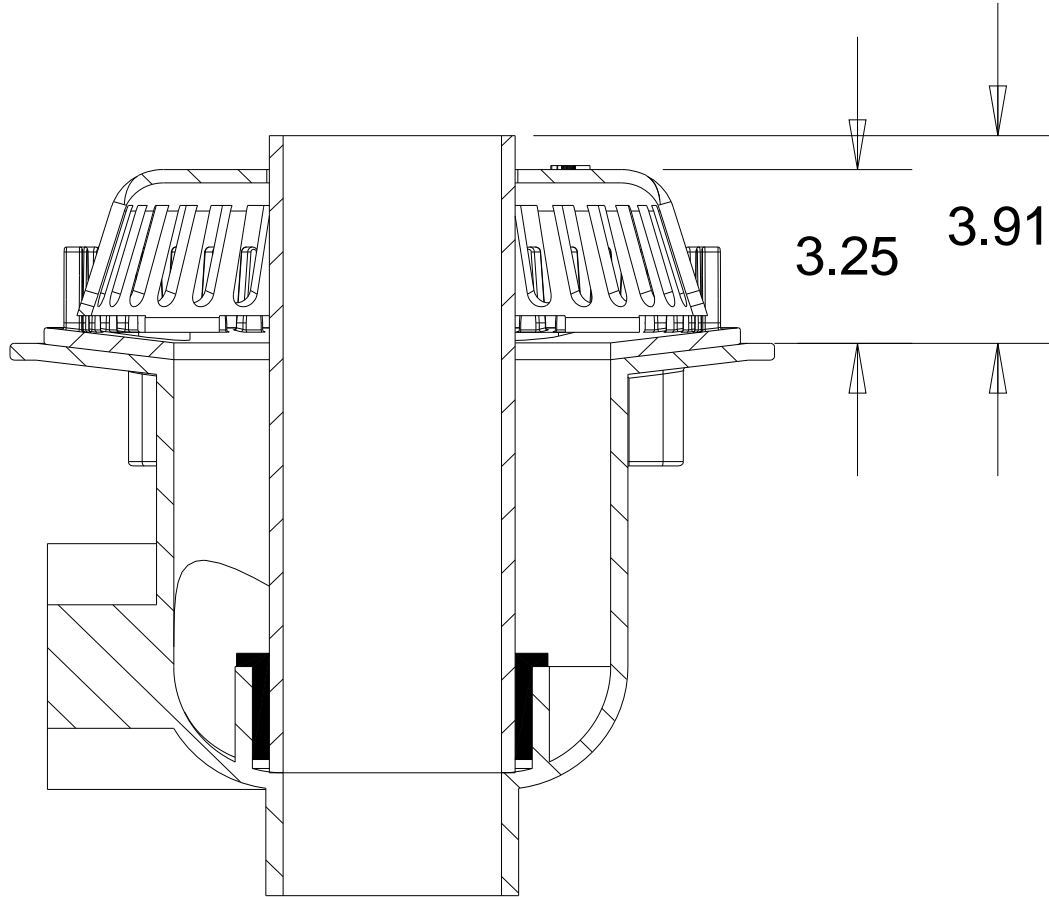

LP	Low Profile	FR	Finishing Ring
DC	Deck Clamp	VP	Vent Pipe
DEX-2	2" Ring Extension	IG	IRMA Roof Guard
DEX-4	4" Ring Extension	SP	Sump Drain Pan
DEX-6	6" Ring Extension	OFSL	Overflow Strainer Low Profile
DP	Drain Pan	DMP	Deck Mounting Plate
OFS	Overflow Strainer	CFW	Control Flow Weir
ER 1.5	Elevation Ring for 1-1/2" Insulation	ER 2	Elevation Ring for 2" Insulation

Specifications subject to change without notice

Froet Drain® Bi-Functional Roof Drain 100C4-90

Patent #US6594966

100C4LP-90-OFSL

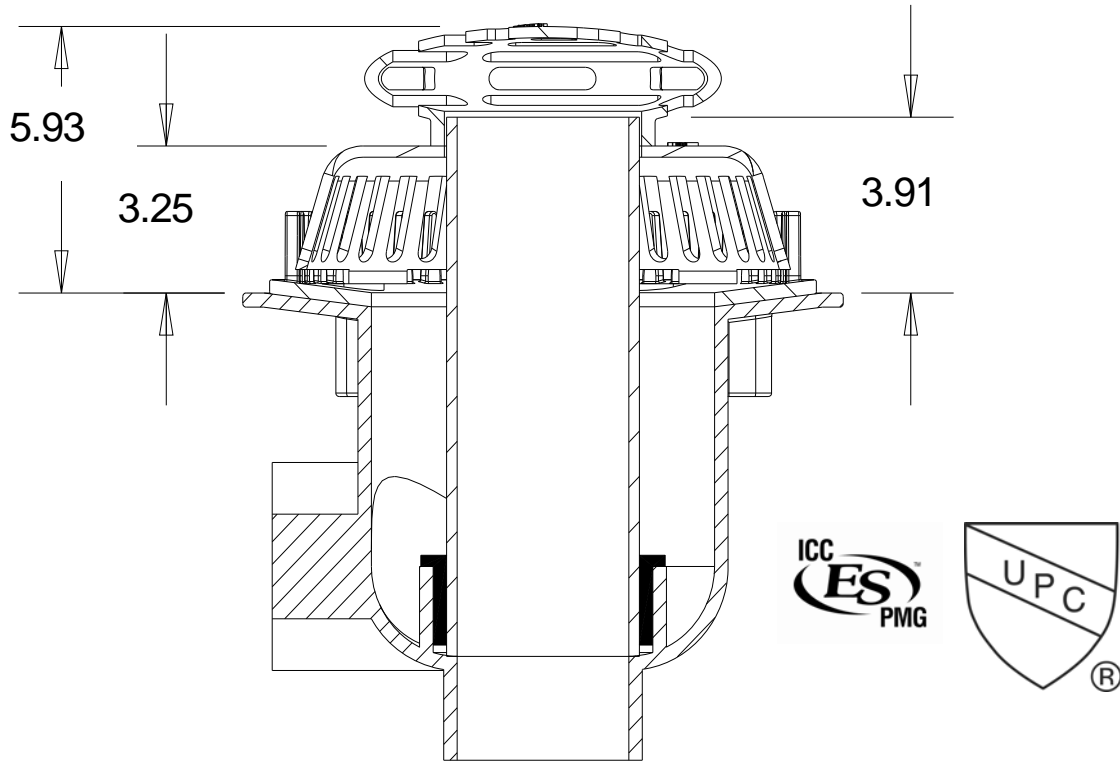

LP	Low Profile	FR	Finishing Ring
DC	Deck Clamp	VP	Vent Pipe
DEX-2	2" Ring Extension	IG	IRMA Roof Guard
DEX-4	4" Ring Extension	SP	Sump Drain Pan
DEX-6	6" Ring Extension	OFSL	Overflow Strainer Low Profile
DP	Drain Pan	DMP	Deck Mounting Plate
OFS	Overflow Strainer	CFW	Control Flow Weir
ER 1.5	Elevation Ring for 1-1/2" Insulation	ER 2	Elevation Ring for 2" Insulation

Specifications subject to change without notice

Froet Drain® Bi-Functional Roof Drain 100C4-90

Patent #US6594966

100C4-DMP

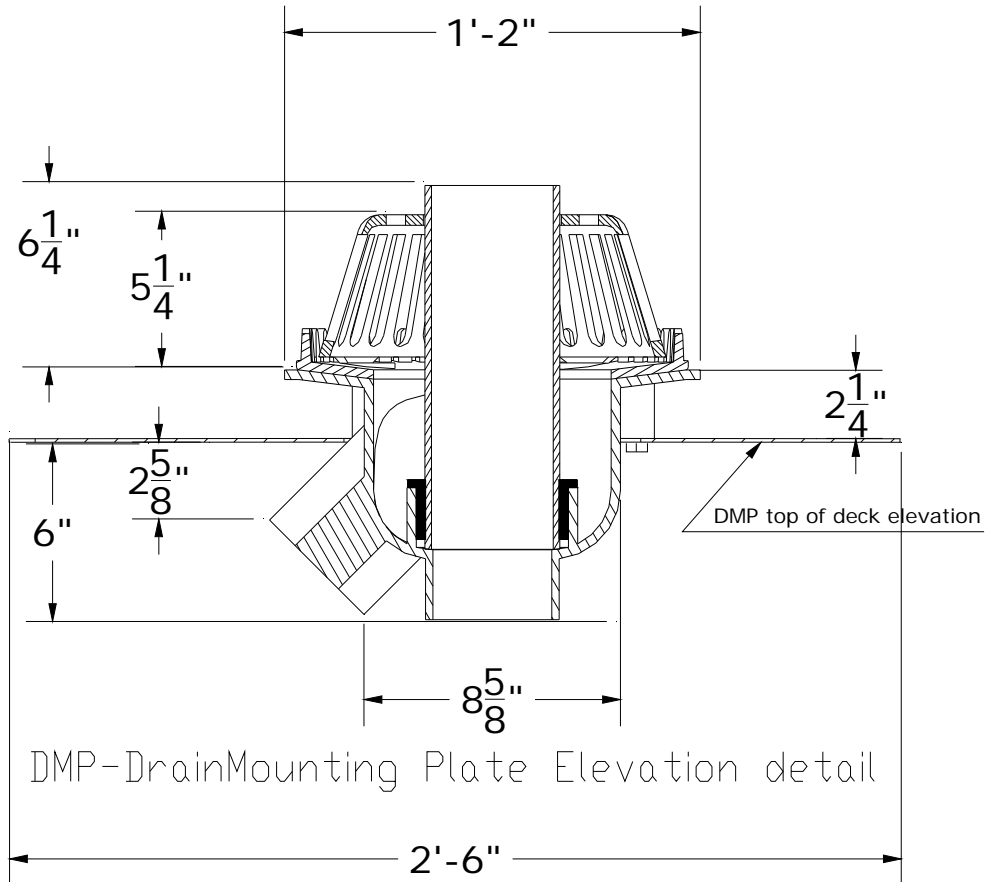

LP	Low Profile	FR	Finishing Ring
DC	Deck Clamp	VP	Vent Pipe
DEX-2	2" Ring Extension	IG	IRMA Roof Guard
DEX-4	4" Ring Extension	SP	Sump Drain Pan
DEX-6	6" Ring Extension	OFSL	Overflow Strainer Low Profile
DP	Drain Pan	DMP	Deck Mounting Plate
OFS	Overflow Strainer	CFW	Control Flow Weir
ER 1.5	Elevation Ring for 1-1/2" Insulation	ER 2	Elevation Ring for 2" Insulation

Specifications subject to change without notice

Froet Drain® Bi-Functional Roof Drain 100C4

Patent #US6594966

100C4-DEX-2-DC

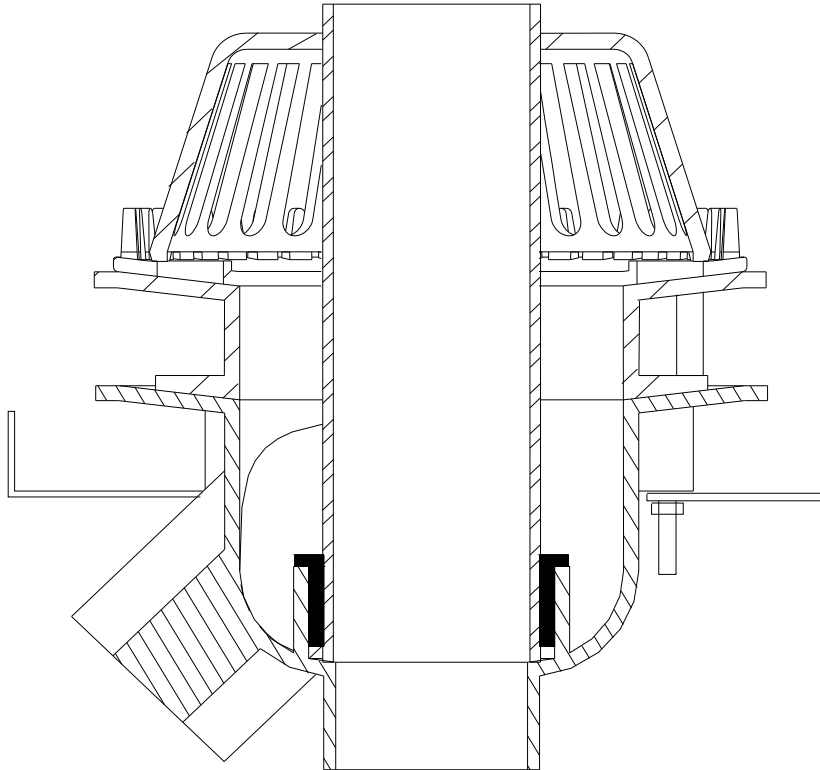

LP	Low Profile	FR	Finishing Ring
DC	Deck Clamp	VP	Vent Pipe
DEX-2	2" Ring Extension	IG	IRMA Roof Guard
DEX-4	4" Ring Extension	SP	Sump Drain Pan
DEX-6	6" Ring Extension	OFSL	Overflow Strainer Low Profile
DP	Drain Pan	DMP	Deck Mounting Plate
OFS	Overflow Strainer	CFW	Control Flow Weir
ER 1.5	Elevation Ring for 1-1/2" Insulation	ER 2	Elevation Ring for 2" Insulation

Specifications subject to change without notice

Froet Drain® Bi-Functional Roof Drain 100C4

Patent #US6594966

100C4-DEX-4-IG

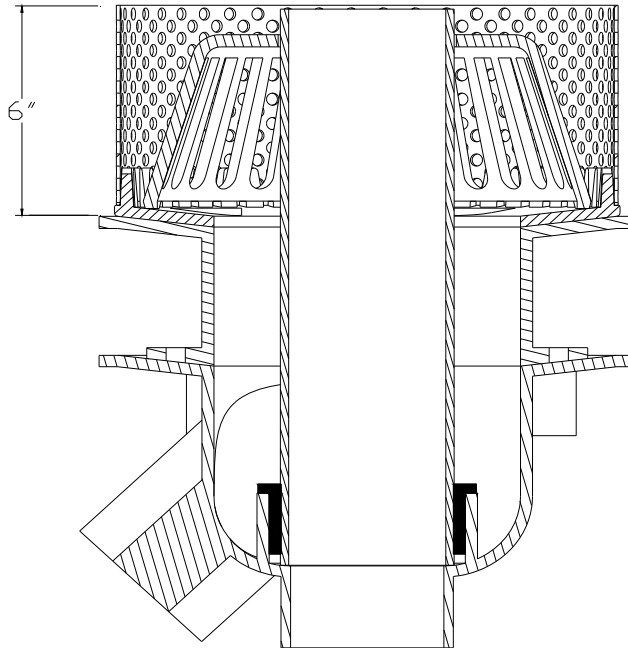

Please Note: The use of the IRMA Guard with a conventional roof system will restrict small debris that would normally pass thru the drainage system. This will block the IRMA Guard and will require increased frequency for maintenance.

LP	Low Profile	FR	Finishing Ring
DC	Deck Clamp	VP	Vent Pipe
DEX-2	2" Ring Extension	IG	IRMA Roof Guard
DEX-4	4" Ring Extension	SP	Sump Drain Pan
DEX-6	6" Ring Extension	OFSL	Overflow Strainer Low Profile
DP	Drain Pan	DMP	Deck Mounting Plate
OFS	Overflow Strainer	CFW	Control Flow Weir
ER 1.5	Elevation Ring for 1-1/2" Insulation	ER 2	Elevation Ring for 2" Insulation

Specifications subject to change without notice

Froet Drain® Bi-Functional Roof Drain 100C4

Patent #US6594966

100C4LP-DEX-6-FR-OFS

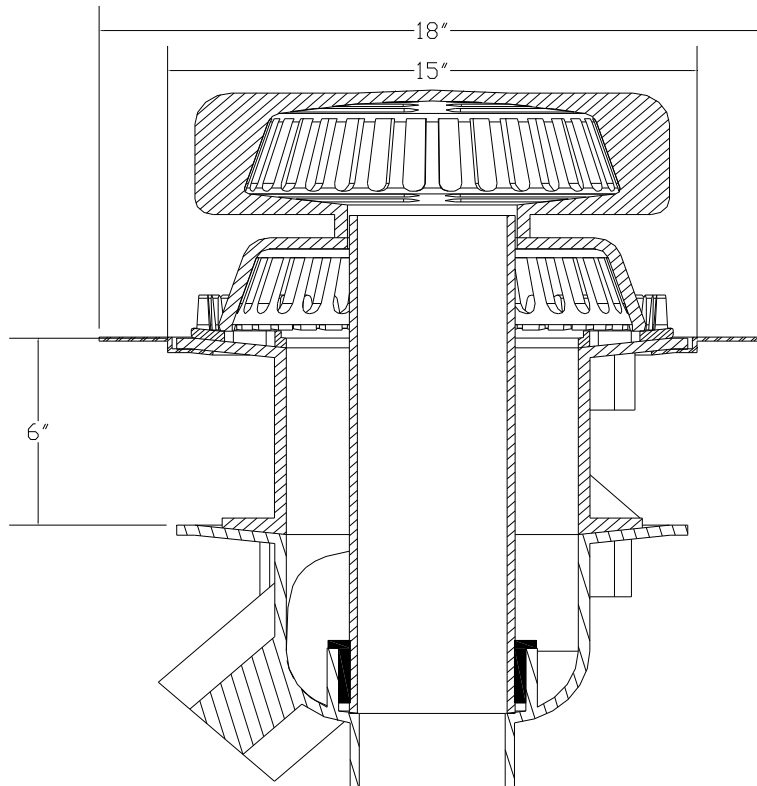

LP	Low Profile	FR	Finishing Ring
DC	Deck Clamp	VP	Vent Pipe
DEX-2	2" Ring Extension	IG	IRMA Roof Guard
DEX-4	4" Ring Extension	SP	Sump Drain Pan
DEX-6	6" Ring Extension	OFSL	Overflow Strainer Low Profile
DP	Drain Pan	DMP	Deck Mounting Plate
OFS	Overflow Strainer	CFW	Control Flow Weir
ER 1.5	Elevation Ring for 1-1/2" Insulation	ER 2	Elevation Ring for 2" Insulation

Specifications subject to change without notice

Froet Drain® Bi-Functional Roof Drain 100C4

Patent #US6594966

100C4-CFW

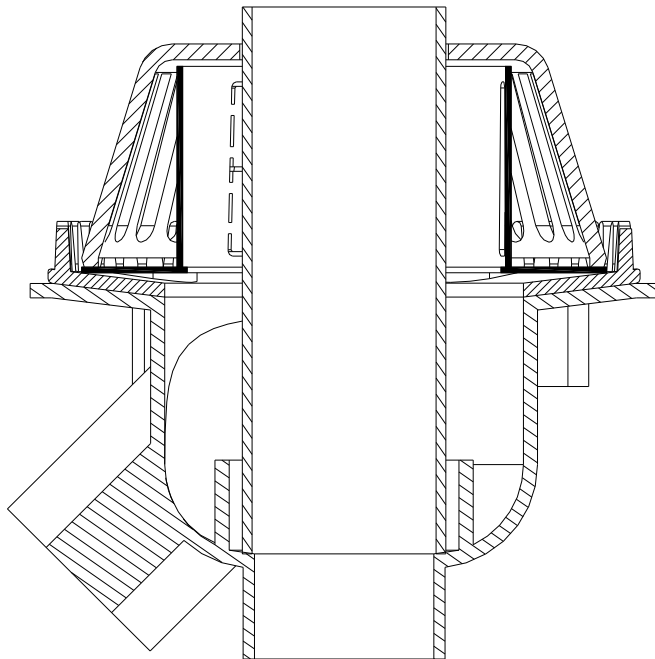

The Froet Drain® roof drain with control flow weir can be configured on the job site for the required amount of flow needed. The weir is produced with one weir open. The 3" and 4" bodies have 6 possible weir openings and the 5" and 6" bodies have 8 possible openings. The chart shows the flow thru one weir opening. The design of our weir also allows for removal of the weir assembly from the drain to facilitate cleaning a plugged drain or piping without breaking the seal with the roofing membrane.

Single Slot Flow verse Head

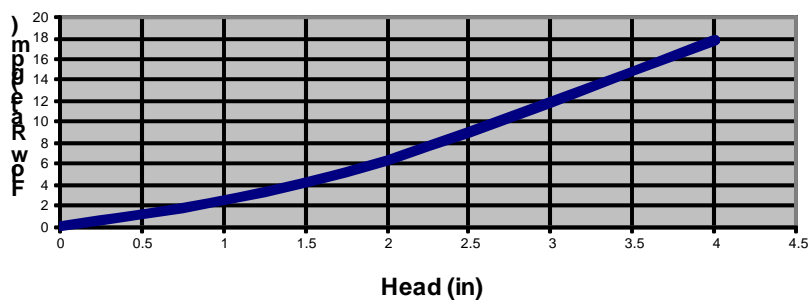

Please note: drain body size will need to be chosen based on the overflow drain requirements. If smaller primary drainage pipe is desired it can be reduced from the drain body outlet

Specifications subject to change without notice

Froet Drain® Bi-Functional Roof Drain 100C4 with vent

Patent # US6594966 & US7415802

100C4-VP

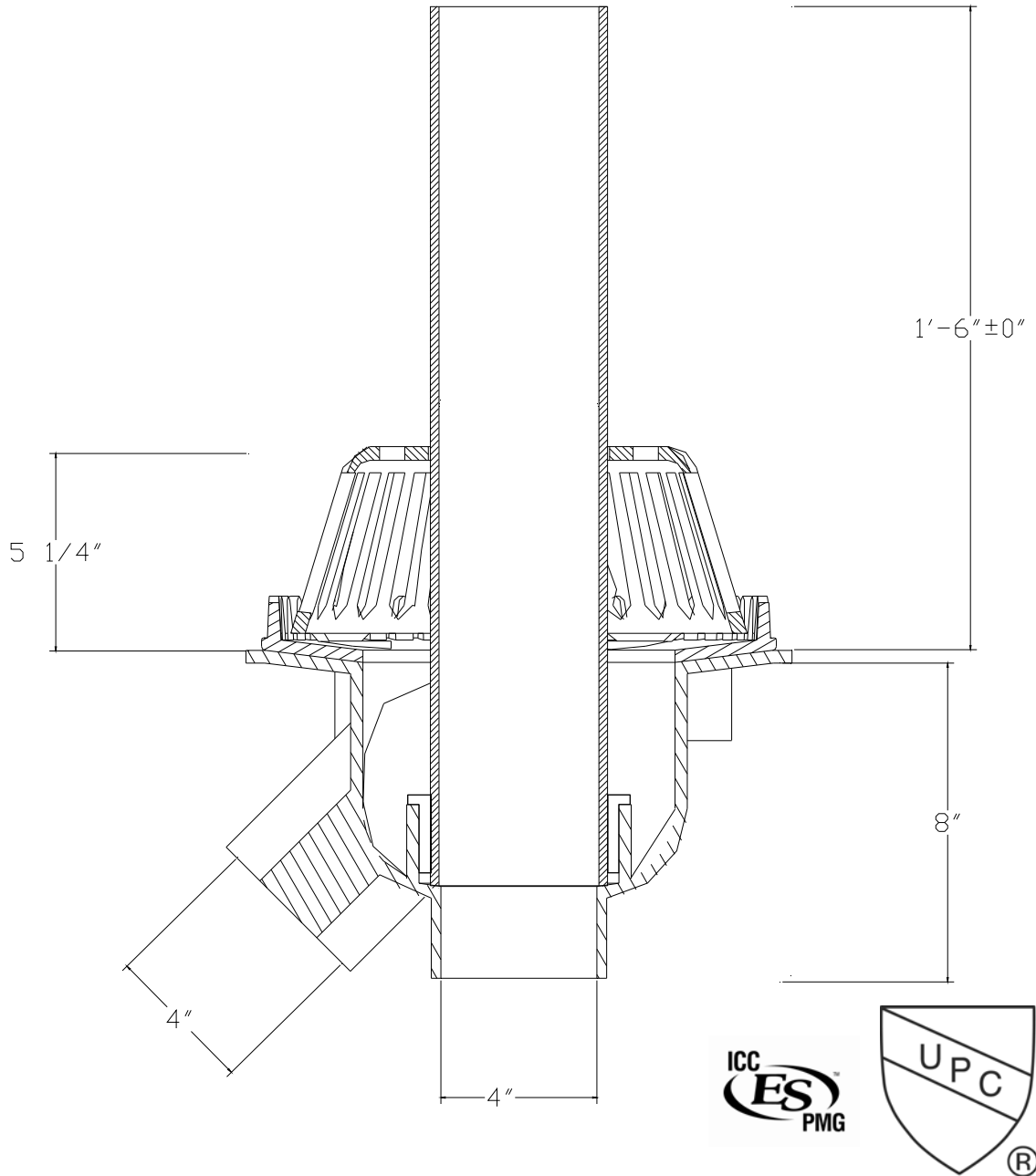

Specifications subject to change without notice

Froet Drain® Bi-Functional Roof Drain 100C5

Patent #US6594966

100 Series 5" Drain Overall Dimensions

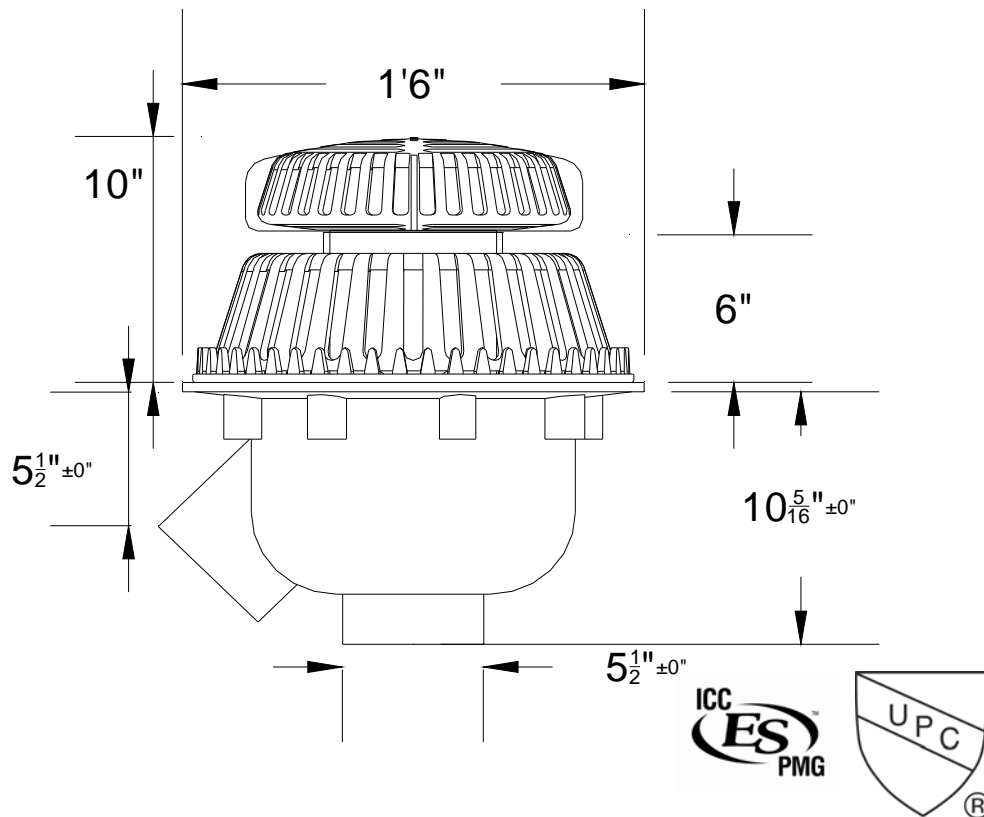

LP	Low Profile	FR	Finishing Ring
DC	Deck Clamp	VP	Vent Pipe
DEX-2	2" Ring Extension	IG	IRMA Roof Guard
DEX-4	4" Ring Extension	SP	Sump Drain Pan
DEX-6	6" Ring Extension	OFSL	Overflow Strainer Low Profile
DP	Drain Pan	DMP	Deck Mounting Plate
OFS	Overflow Strainer	CFW	Control Flow Weir
ER 1.5	Elevation Ring for 1-1/2" Insulation	ER 2	Elevation Ring for 2" Insulation

Specifications subject to change without notice

Froet Drain® Bi-Functional Roof Drain 100C5

Patent #US6594966

100C5LP-OFS

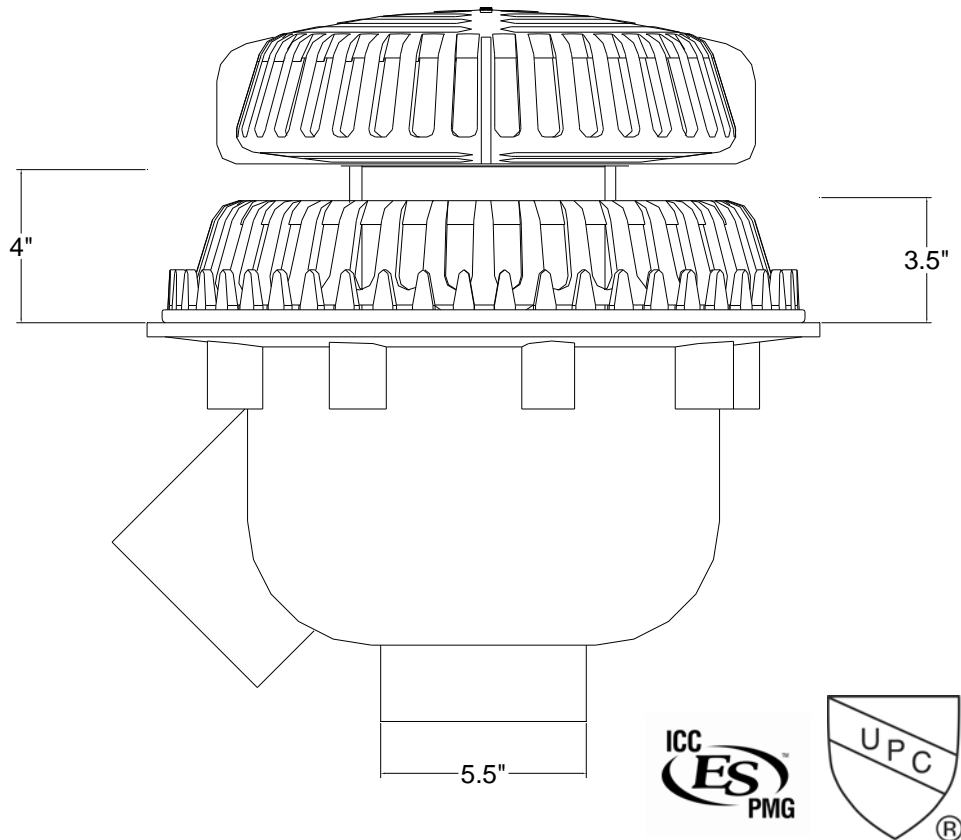

LP	Low Profile	FR	Finishing Ring
DC	Deck Clamp	VP	Vent Pipe
DEX-2	2" Ring Extension	IG	IRMA Roof Guard
DEX-4	4" Ring Extension	SP	Sump Drain Pan
DEX-6	6" Ring Extension	OFSL	Overflow Strainer Low Profile
DP	Drain Pan	DMP	Deck Mounting Plate
OFS	Overflow Strainer	CFW	Control Flow Weir
ER 1.5	Elevation Ring for 1-1/2" Insulation	ER 2	Elevation Ring for 2" Insulation

Specifications subject to change without notice

Froet Drain® Bi-Functional Roof Drain 100C6

Patent #US6594966

100 Series 6" Drain Overall Dimensions

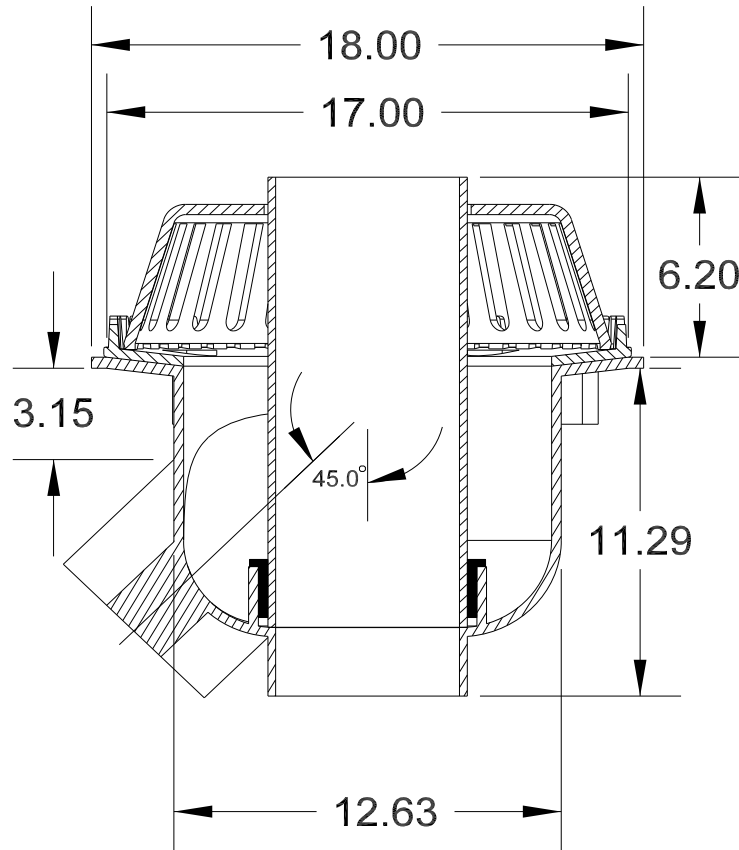

LP	Low Profile	FR	Finishing Ring
DC	Deck Clamp	VP	Vent Pipe
DEX-2	2" Ring Extension	IG	IRMA Roof Guard
DEX-4	4" Ring Extension	SP	Sump Drain Pan
DEX-6	6" Ring Extension	OFSL	Overflow Strainer Low Profile
DP	Drain Pan	DMP	Deck Mounting Plate
OFS	Overflow Strainer	CFW	Control Flow Weir
ER 1.5	Elevation Ring for 1-1/2" Insulation	ER 2	Elevation Ring for 2" Insulation

Specifications subject to change without notice

Froet Drain® Bi-Functional Roof Drain 100C6

Patent #US6594966

Dimensions with overflow strainer

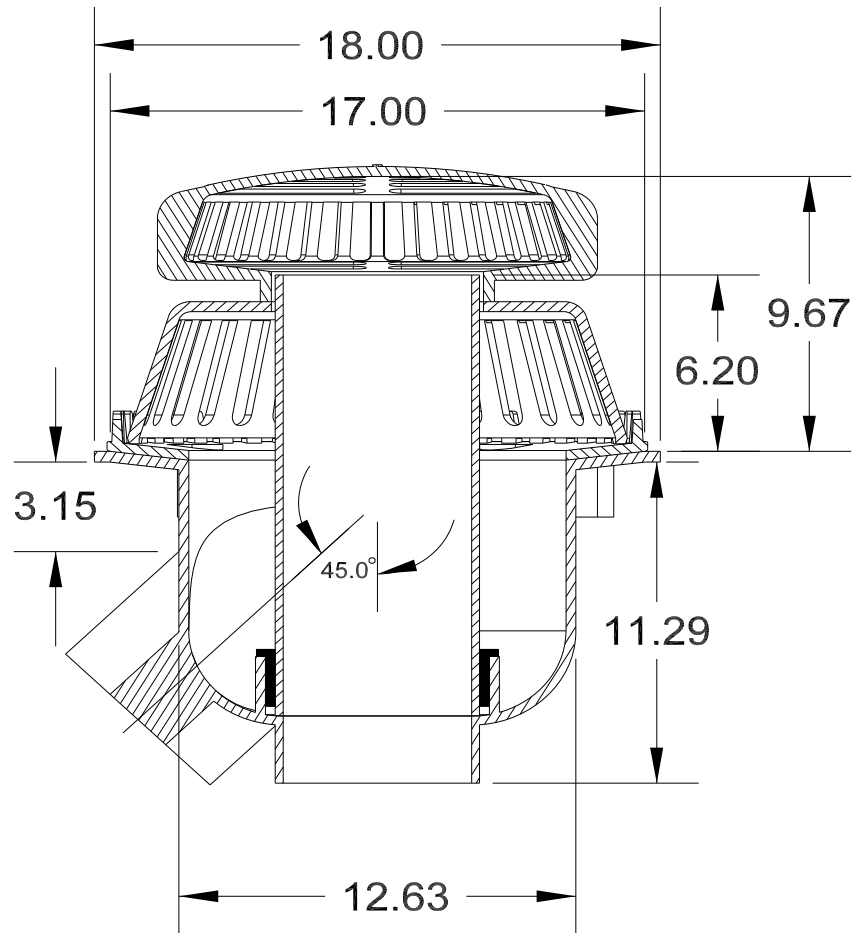

LP	Low Profile	FR	Finishing Ring
DC	Deck Clamp	VP	Vent Pipe
DEX-2	2" Ring Extension	IG	IRMA Roof Guard
DEX-4	4" Ring Extension	SP	Sump Drain Pan
DEX-6	6" Ring Extension	OFSL	Overflow Strainer Low Profile
DP	Drain Pan	DMP	Deck Mounting Plate
OFS	Overflow Strainer	CFW	Control Flow Weir
ER 1.5	Elevation Ring for 1-1/2" Insulation	ER 2	Elevation Ring for 2" Insulation

Specifications subject to change without notice

Froet Drain® Bi-Functional Roof Drain 100C6

Patent #US6594966

100C6

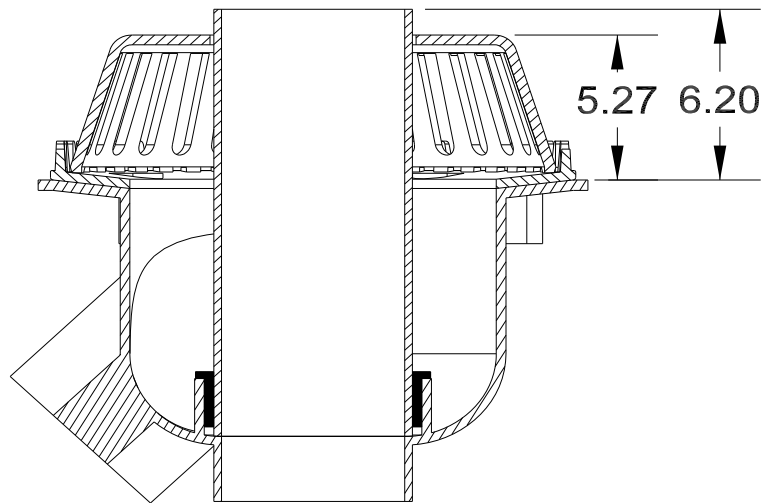

LP	Low Profile	FR	Finishing Ring
DC	Deck Clamp	VP	Vent Pipe
DEX-2	2" Ring Extension	IG	IRMA Roof Guard
DEX-4	4" Ring Extension	SP	Sump Drain Pan
DEX-6	6" Ring Extension	OFSL	Overflow Strainer Low Profile
DP	Drain Pan	DMP	Deck Mounting Plate
OFS	Overflow Strainer	CFW	Control Flow Weir
ER 1.5	Elevation Ring for 1-1/2" Insulation	ER 2	Elevation Ring for 2" Insulation

Specifications subject to change without notice

Froet Drain® Bi-Functional Roof Drain 100C6

Patent #US6594966

100C6-FR

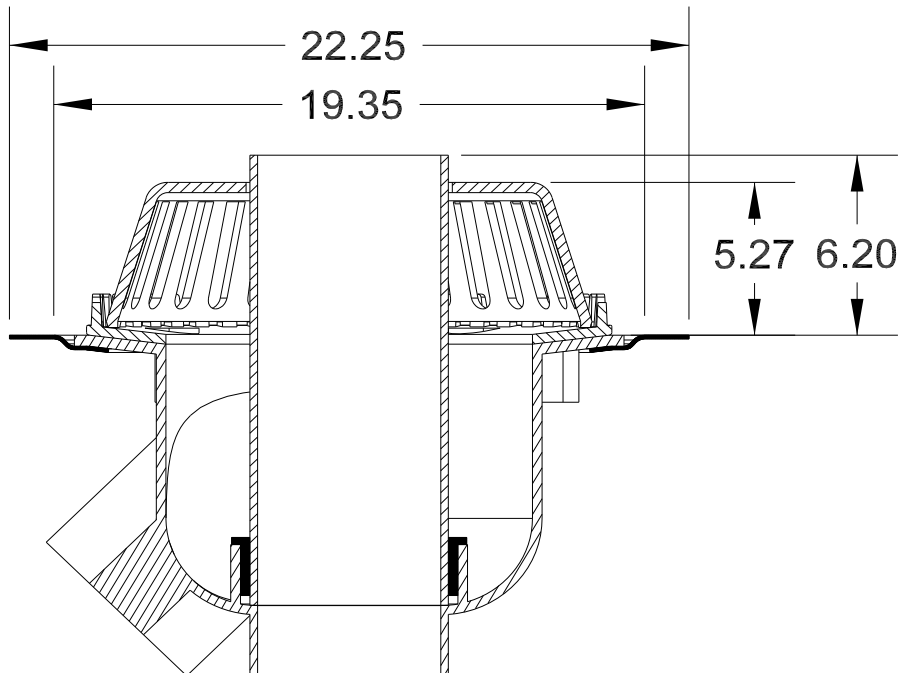

LP	Low Profile	FR	Finishing Ring
DC	Deck Clamp	VP	Vent Pipe
DEX-2	2" Ring Extension	IG	IRMA Roof Guard
DEX-4	4" Ring Extension	SP	Sump Drain Pan
DEX-6	6" Ring Extension	OFSL	Overflow Strainer Low Profile
DP	Drain Pan	DMP	Deck Mounting Plate
OFS	Overflow Strainer	CFW	Control Flow Weir
ER 1.5	Elevation Ring for 1-1/2" Insulation	ER 2	Elevation Ring for 2" Insulation

Specifications subject to change without notice

Froet Drain® Bi-Functional Roof Drain 100C6

Patent #US6594966

100C6LP

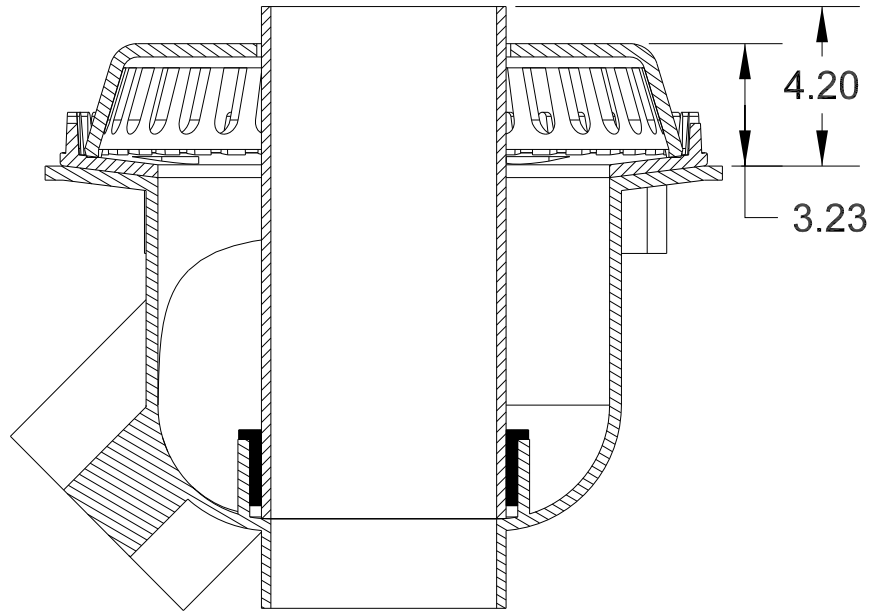

LP	Low Profile	FR	Finishing Ring
DC	Deck Clamp	VP	Vent Pipe
DEX-2	2" Ring Extension	IG	IRMA Roof Guard
DEX-4	4" Ring Extension	SP	Sump Drain Pan
DEX-6	6" Ring Extension	OFSL	Overflow Strainer Low Profile
DP	Drain Pan	DMP	Deck Mounting Plate
OFS	Overflow Strainer	CFW	Control Flow Weir
ER 1.5	Elevation Ring for 1-1/2" Insulation	ER 2	Elevation Ring for 2" Insulation

Specifications subject to change without notice

Froet Drain® Bi-Functional Roof Drain 100C6

Patent #US6594966

100C6LP-OFS

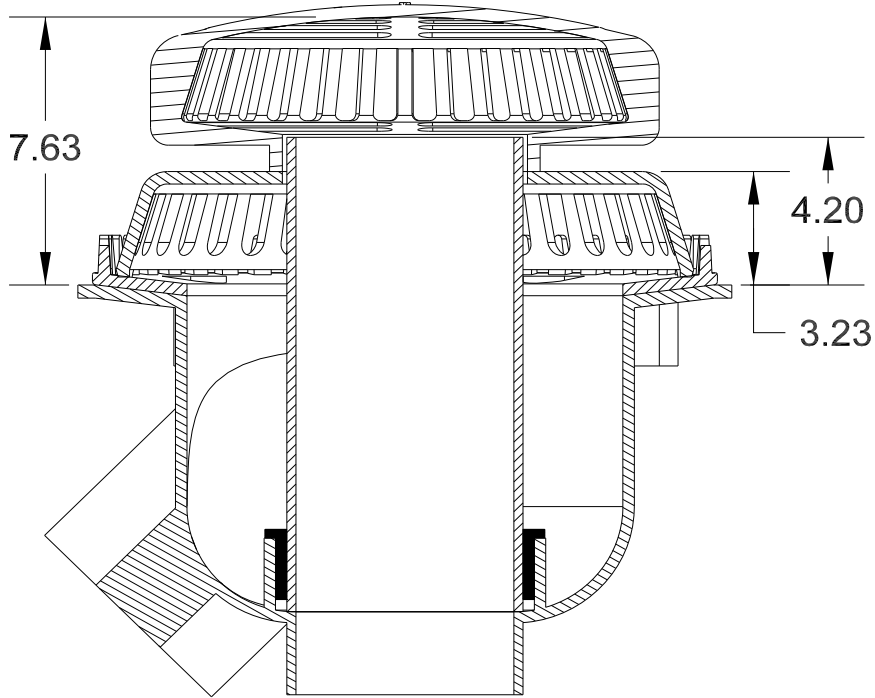

LP	Low Profile	FR	Finishing Ring
DC	Deck Clamp	VP	Vent Pipe
DEX-2	2" Ring Extension	IG	IRMA Roof Guard
DEX-4	4" Ring Extension	SP	Sump Drain Pan
DEX-6	6" Ring Extension	OFSL	Overflow Strainer Low Profile
DP	Drain Pan	DMP	Deck Mounting Plate
OFS	Overflow Strainer	CFW	Control Flow Weir
ER 1.5	Elevation Ring for 1-1/2" Insulation	ER 2	Elevation Ring for 2" Insulation

Specifications subject to change without notice

Froet Drain® Bi-Functional Roof Drain 100C6

Patent #US6594966

100C6LP-FR-DC

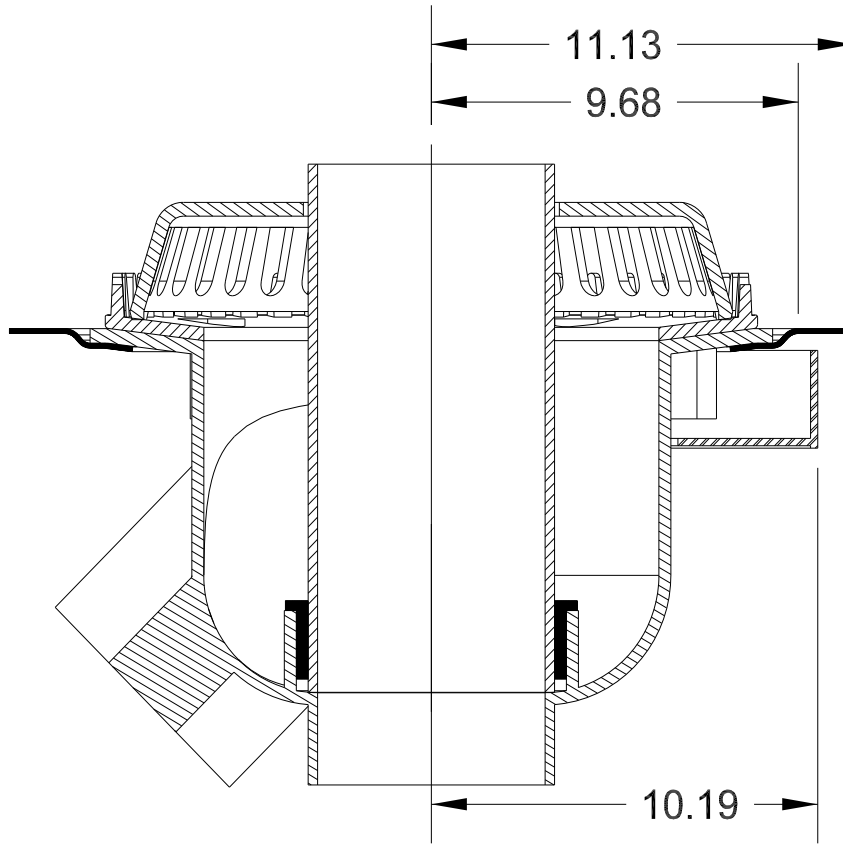

LP	Low Profile	FR	Finishing Ring
DC	Deck Clamp	VP	Vent Pipe
DEX-2	2" Ring Extension	IG	IRMA Roof Guard
DEX-4	4" Ring Extension	SP	Sump Drain Pan
DEX-6	6" Ring Extension	OFSL	Overflow Strainer Low Profile
DP	Drain Pan	DMP	Deck Mounting Plate
OFS	Overflow Strainer	CFW	Control Flow Weir
ER 1.5	Elevation Ring for 1-1/2" Insulation	ER 2	Elevation Ring for 2" Insulation

Specifications subject to change without notice

Froet Drain® Bi-Functional Roof Drain 100C6

Patent #US6594966

100C6-DEX-4-FR

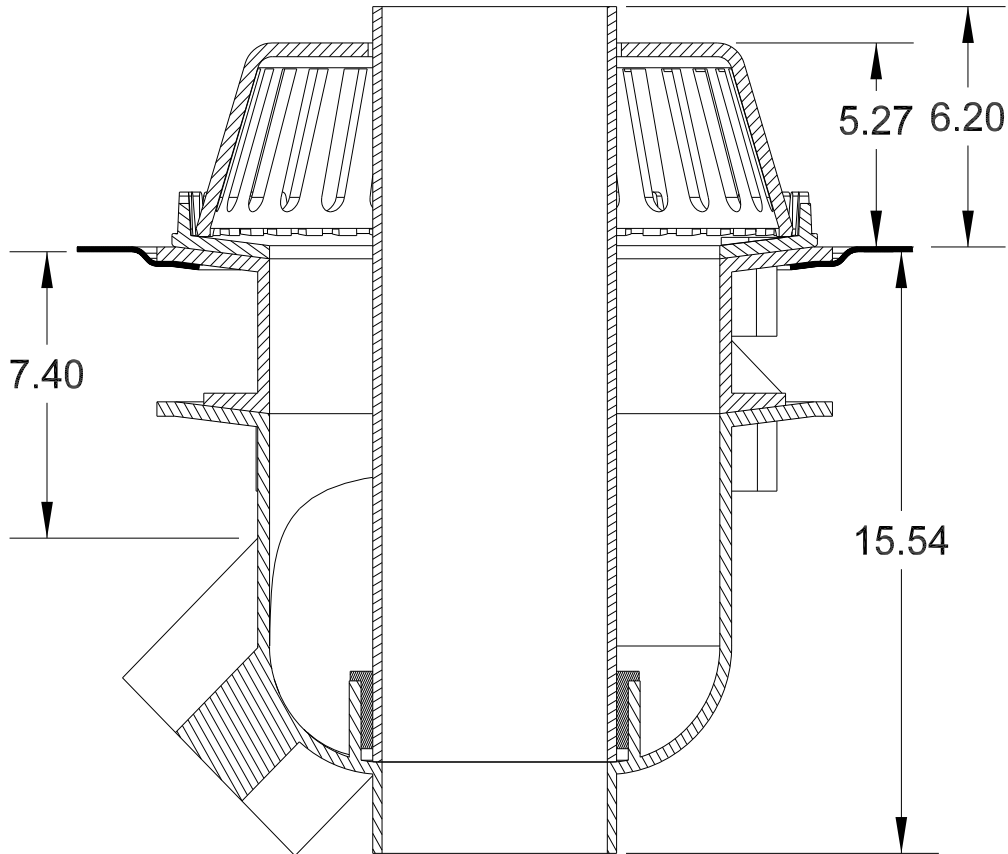

LP	Low Profile	FR	Finishing Ring
DC	Deck Clamp	VP	Vent Pipe
DEX-2	2" Ring Extension	IG	IRMA Roof Guard
DEX-4	4" Ring Extension	SP	Sump Drain Pan
DEX-6	6" Ring Extension	OFSL	Overflow Strainer Low Profile
DP	Drain Pan	DMP	Deck Mounting Plate
OFS	Overflow Strainer	CFW	Control Flow Weir
ER 1.5	Elevation Ring for 1-1/2" Insulation	ER 2	Elevation Ring for 2" Insulation

Specifications subject to change without notice

Froet Drain® Bi-Functional Roof Drain 100C6-CFW

Patent #US6594966

100C6-CFW

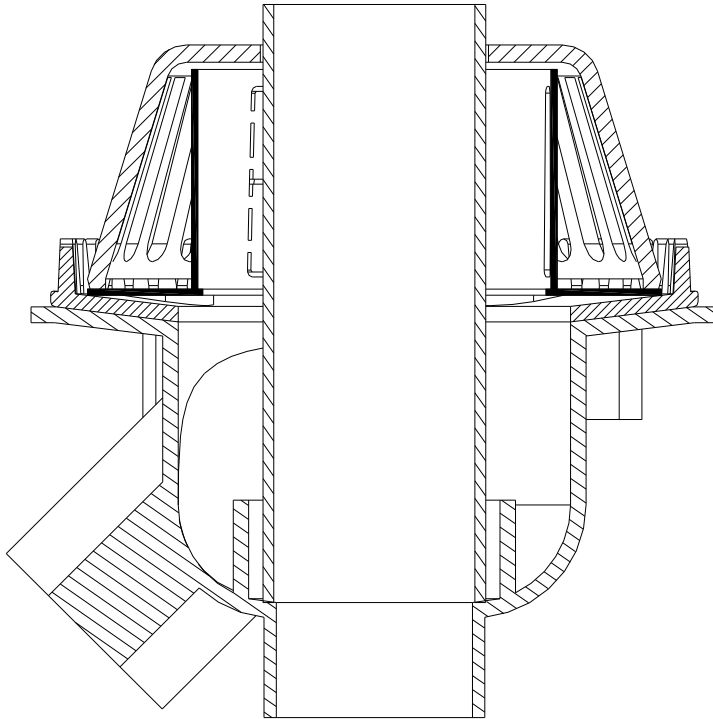

The Froet Drain® roof drain with control flow weir can be configured on the job site for the required amount of flow needed. The weir is produced with one weir open. The 3" and 4" bodies have 6 possible weir openings and the 5" and 6" bodies have 8 possible openings. The chart shows the flow thru one weir opening. The design of our weir also allows for removal of the weir assembly from the drain to facilitate cleaning a plugged drain or piping without breaking the seal with the roofing membrane.

Single Slot Flow verse Head

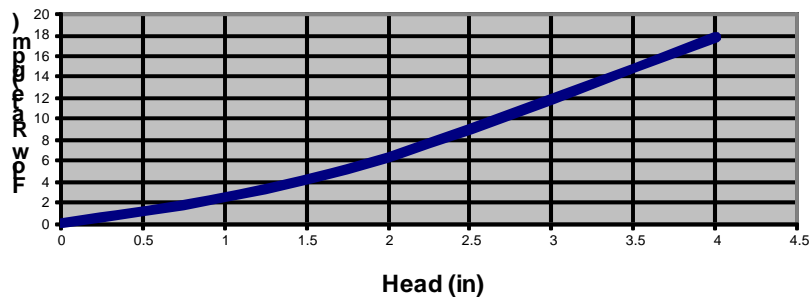

Please note: drain body size will need to be chosen based on the overflow drain requirements. If smaller primary drainage pipe is desired it can be reduced from the drain body outlet

Specifications subject to change without notice

Froet Drain® Bi-Functional Roof Drain 100C6 with vent

Patent # US6594966 & US7415802

100C6-VP

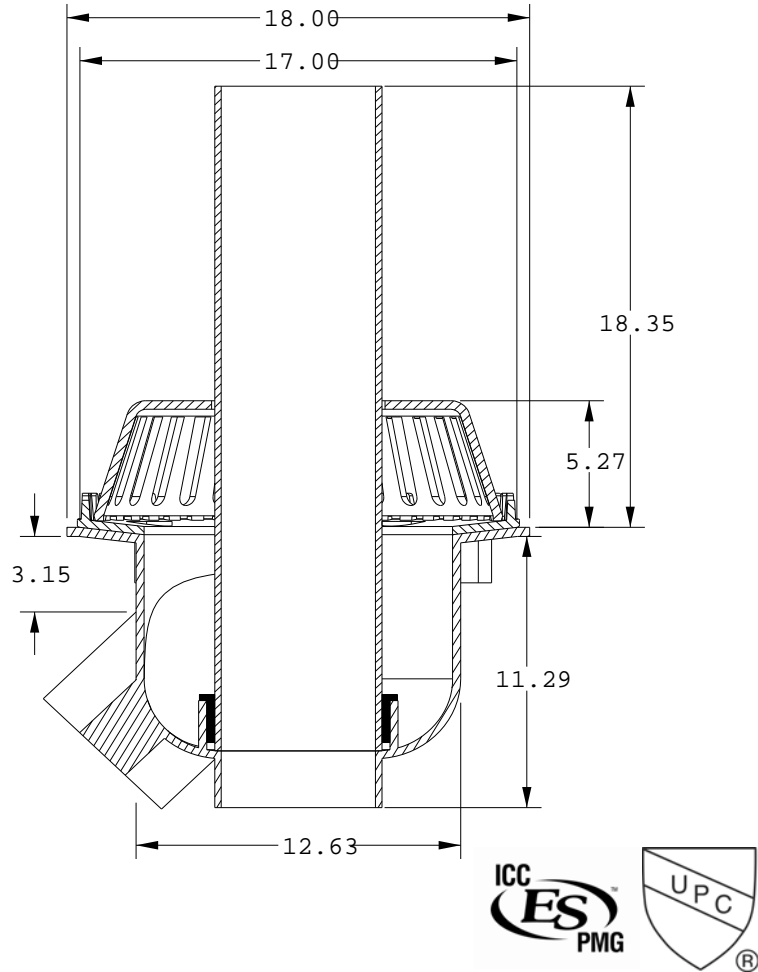

LP	Low Profile	FR	Finishing Ring
DC	Deck Clamp	VP	Vent Pipe
DEX-2	2" Ring Extension	IG	IRMA Roof Guard
DEX-4	4" Ring Extension	SP	Sump Drain Pan
DEX-6	6" Ring Extension	OFSL	Overflow Strainer Low Profile
DP	Drain Pan	DMP	Deck Mounting Plate
OFS	Overflow Strainer	CFW	Control Flow Weir
ER 1.5	Elevation Ring for 1-1/2" Insulation	ER 2	Elevation Ring for 2" Insulation

Specifications subject to change without notice

Froet Drain® Bi-Functional Roof Drain 100C8

Patent # US6594966

100C8

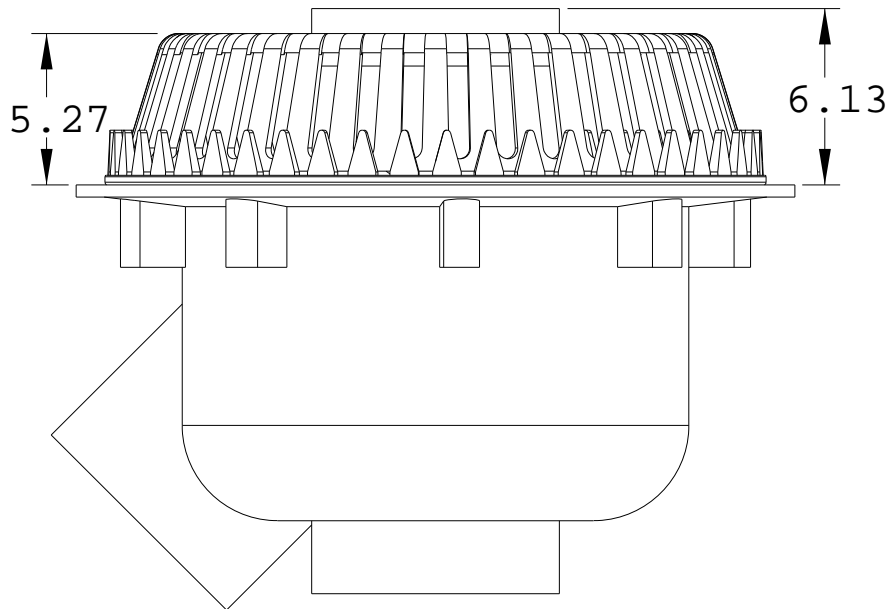

LP	Low Profile	DMP	Deck Mounting Plate
DC	Deck Clamp	OFS	Over Flow Strainer
DP	Drain Pan		

Specifications subject to change without notice

Froet Drain® Bi-Functional Roof Drain 100C8

Patent # US6594966

100C8-LP

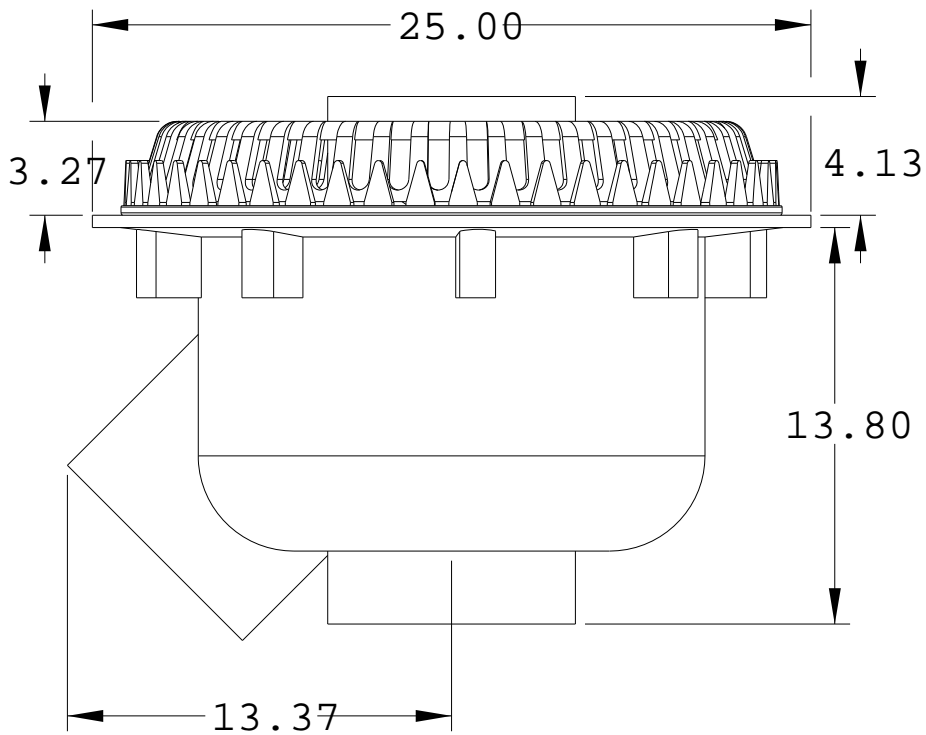

LP	Low Profile	DMP	Deck Mounting Plate
DC	Deck Clamp	OFS	Over Flow Strainer
DP	Drain Pan		

Specifications subject to change without notice

Froet Drain® Bi-Functional Roof Drain 100C8

Patent # US6594966

100C8-OFS

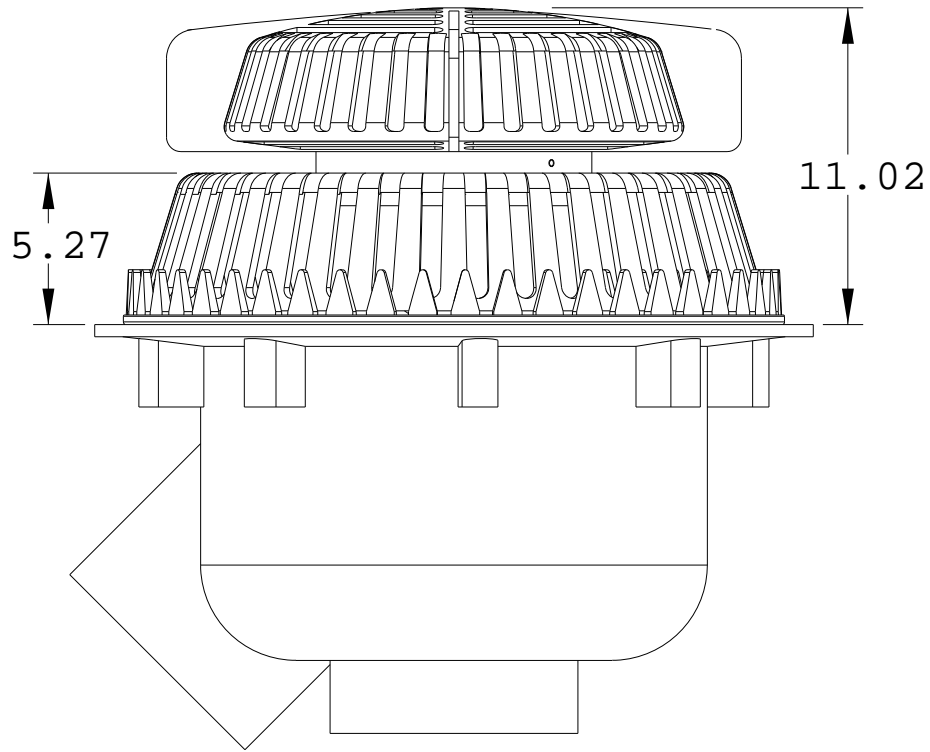

LP	Low Profile	DMP	Deck Mounting Plate
DC	Deck Clamp	OFS	Over Flow Strainer
DP	Drain Pan		

Specifications subject to change without notice

Froet Drain® Bi-Functional Roof Drain 100C8

Patent # US6594966

100C8LP-OFS

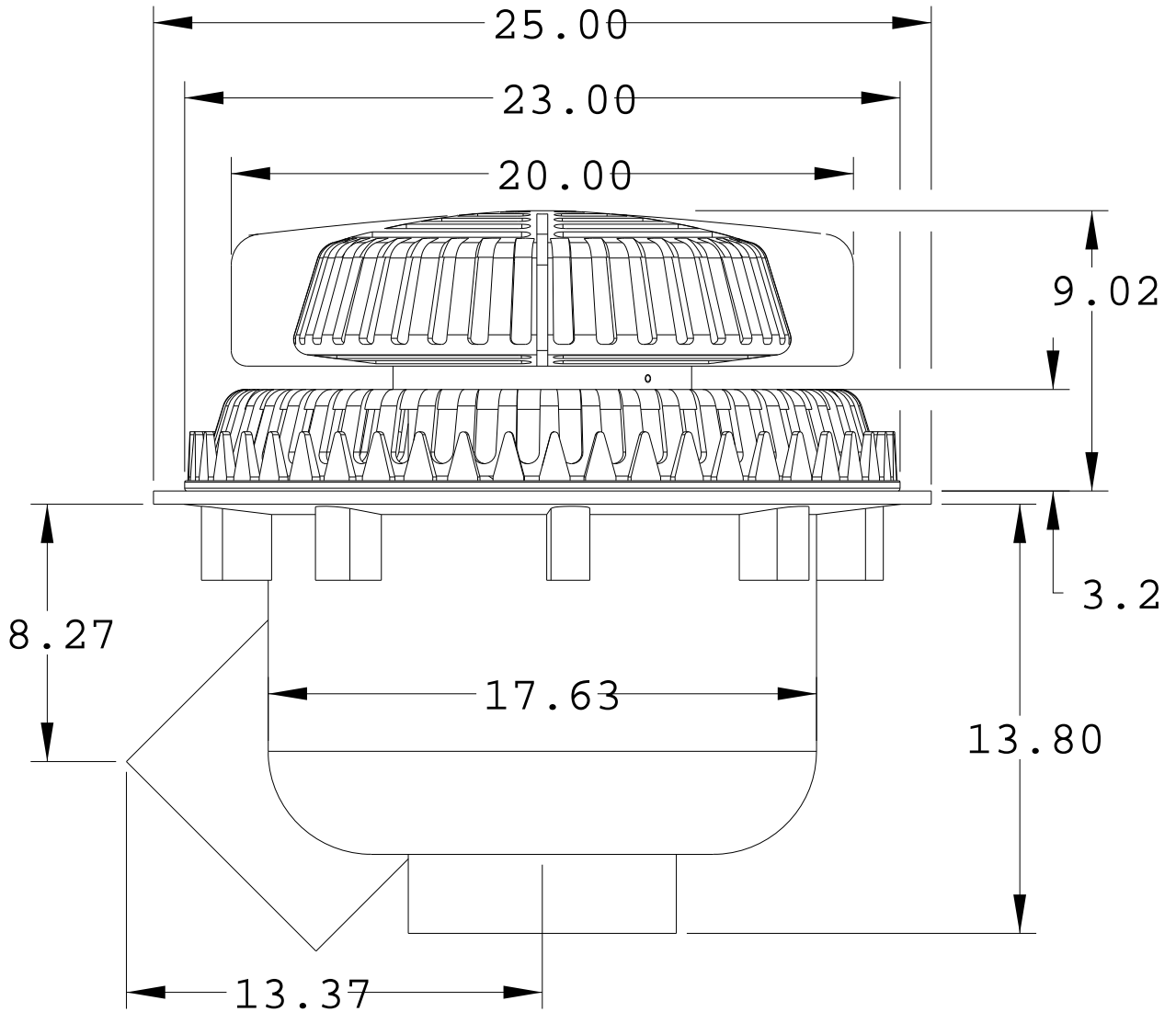

LP	Low Profile	DMP	Deck Mounting Plate
DC	Deck Clamp	OFS	Over Flow Strainer
DP	Drain Pan		

Specifications subject to change without notice

Froet Drain® Bi-Functional Roof Drain 100C8

Patent # US6594966

100C8-DC

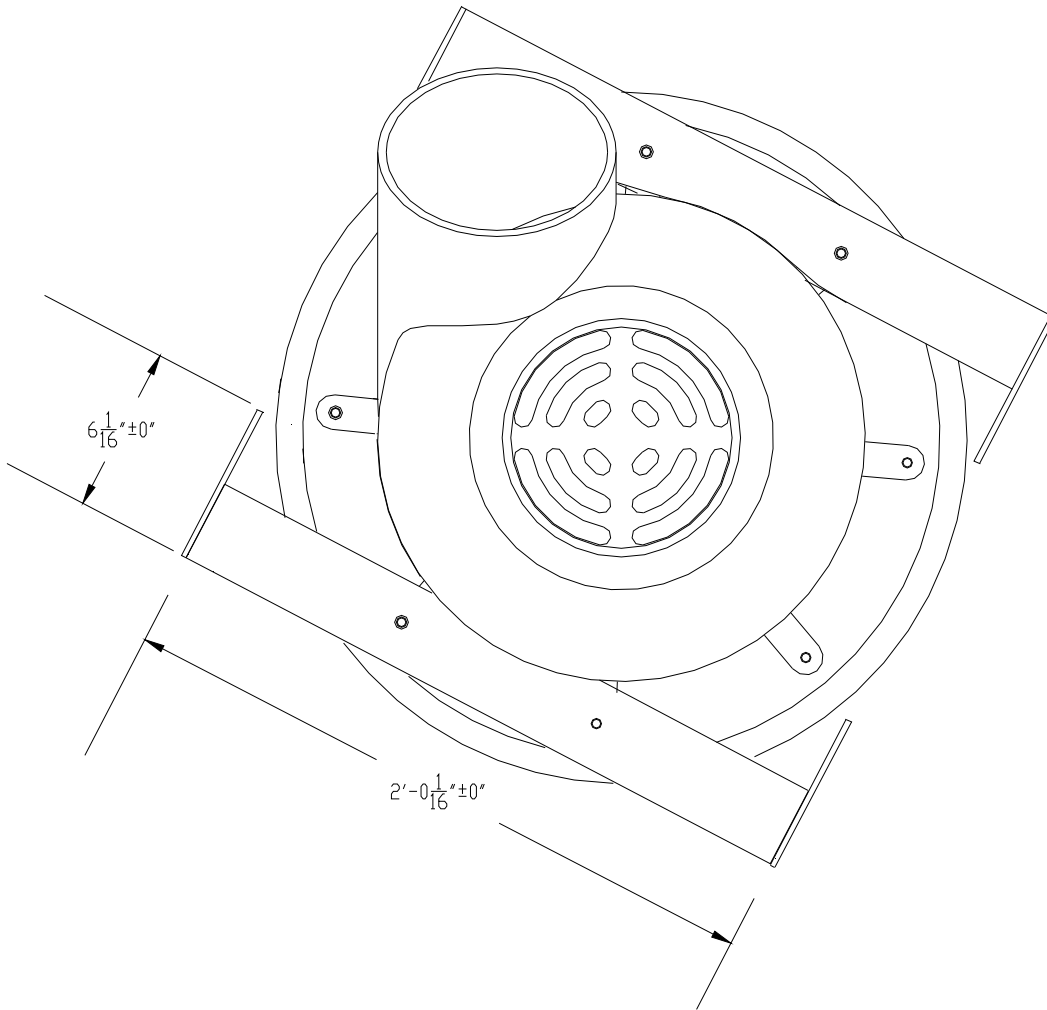

LP	Low Profile	DMP	Deck Mounting Plate
DC	Deck Clamp	OFS	Over Flow Strainer
DP	Drain Pan		

Specifications subject to change without notice

Alternate installations for the Froet Drain® roof drain

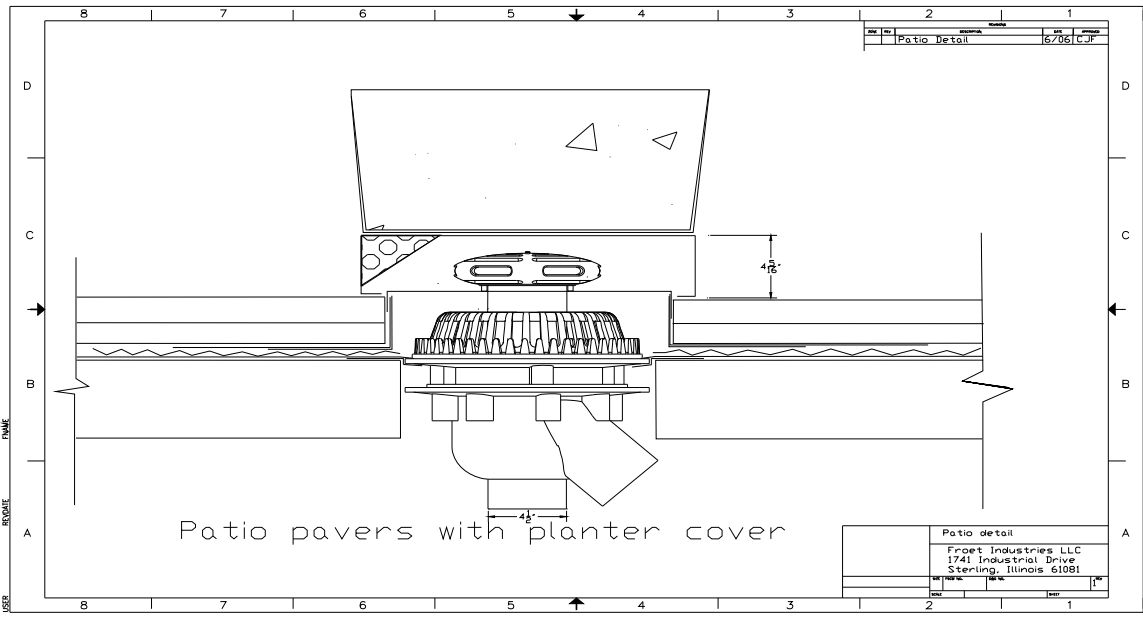
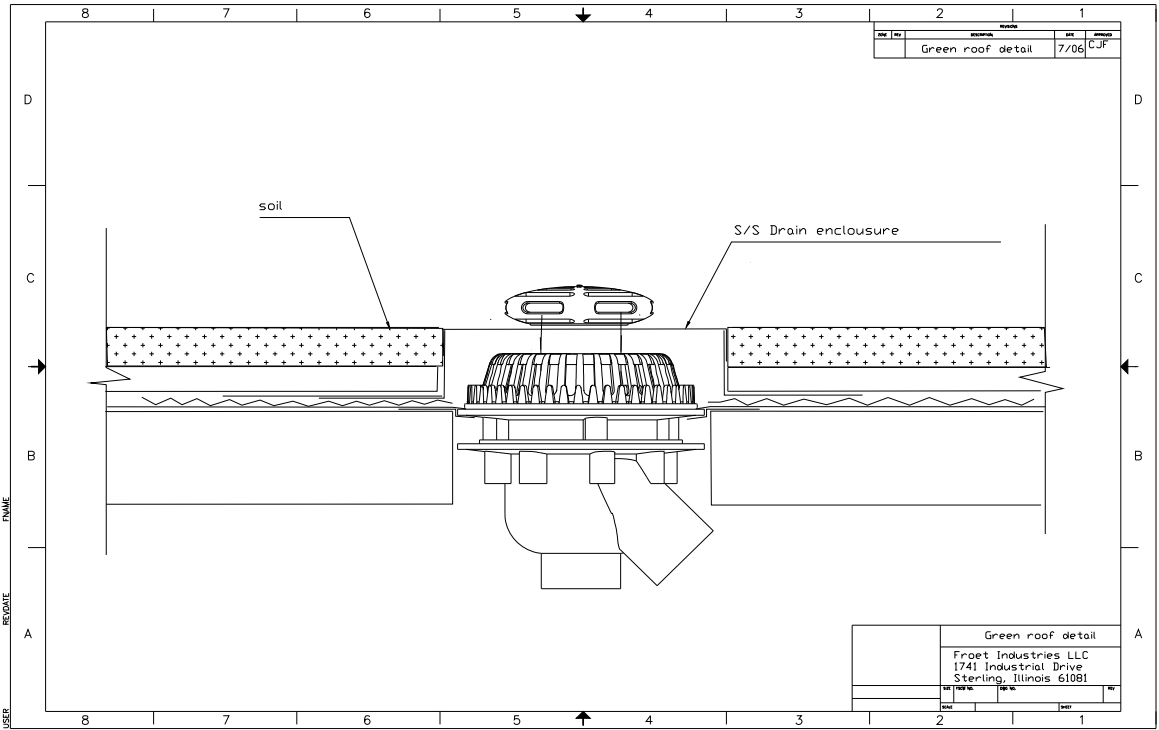

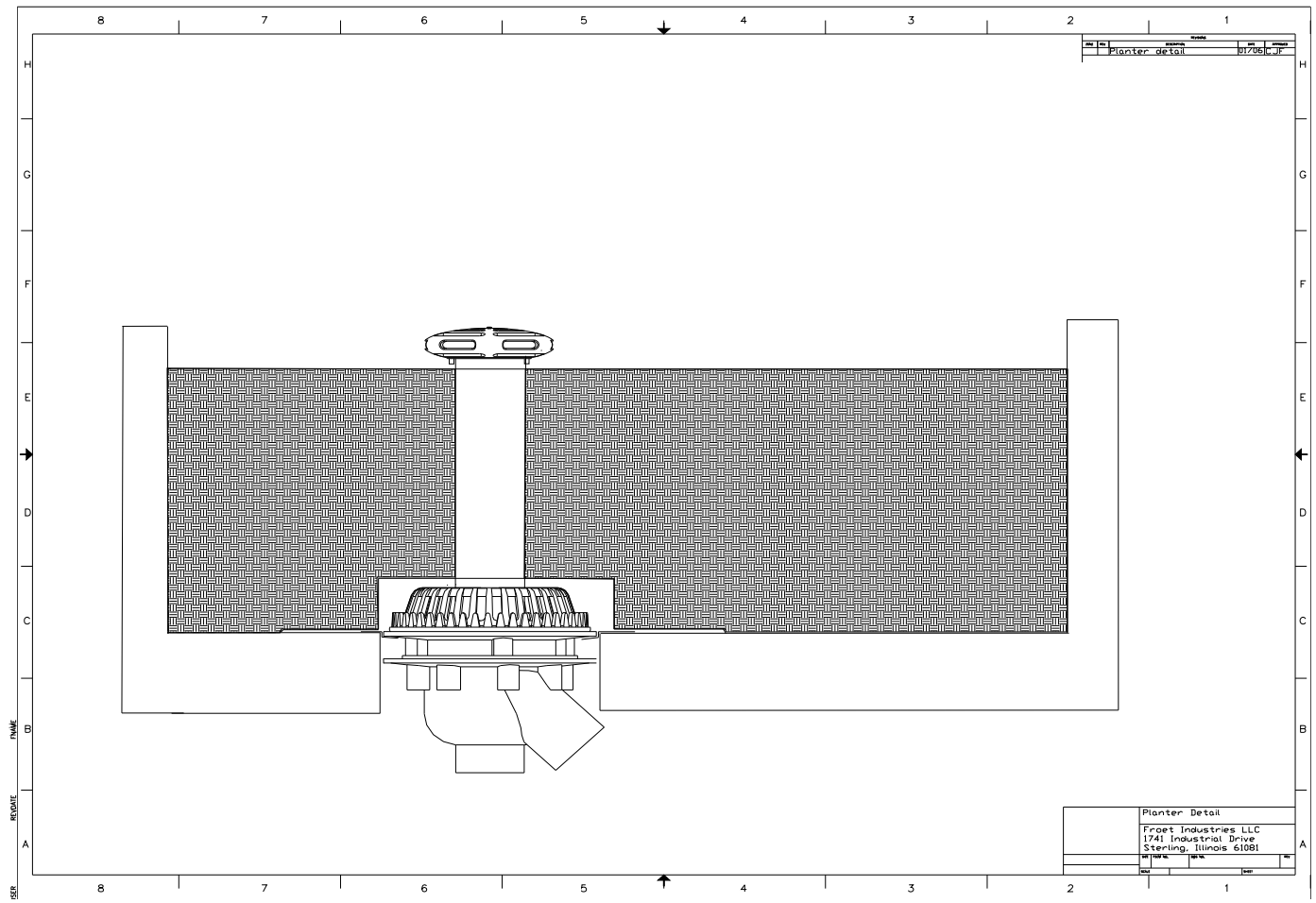

Froet Standard Roof Drain 200C3

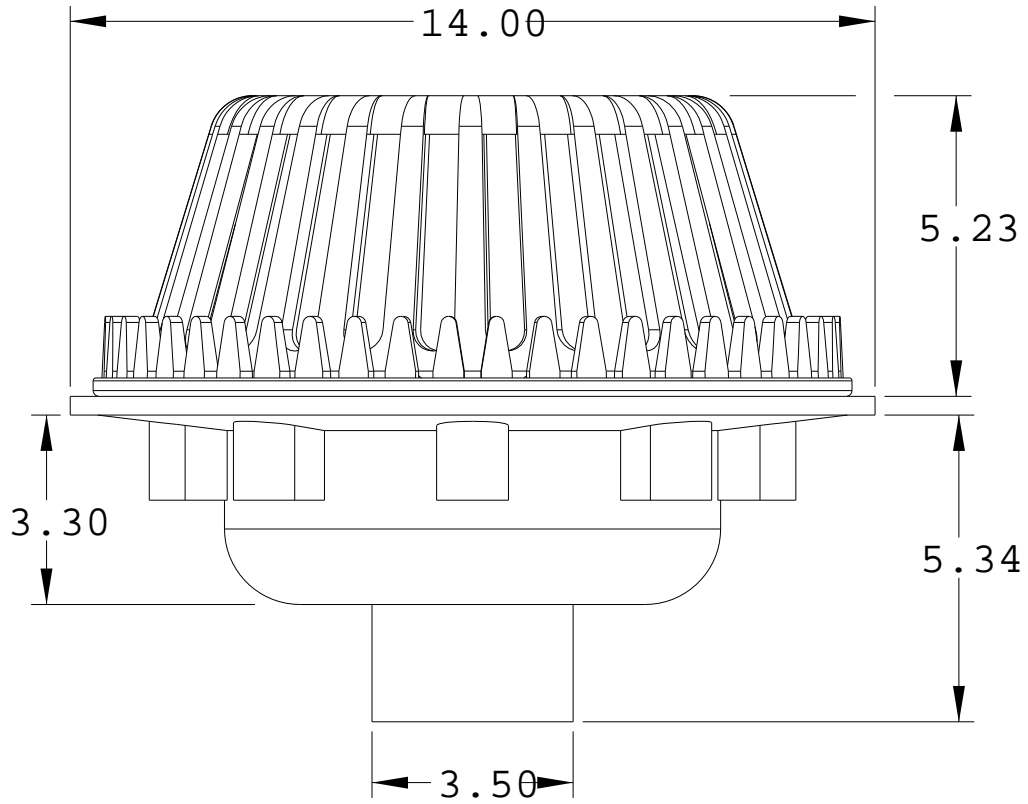

DC	Deck Clamp	FR	Finishing Ring
DEX-2	2" Ring Extension	IG	IRMA Roof Guard
DEX-4	4" Ring Extension	SP	Sump Drain Pan
DEX-6	6" Ring Extension	DMP	Deck Mounting Plate
DP	Drain Pan	CFW	Control Flow Weir

Specifications subject to change without notice

Froet Industries LLC - P.O. Box 787 -1741 Industrial Drive-Sterling, Illinois 61081 - ph.815.626.7922 fx.815.626.0702
www.froetindustries.com

Froet Standard Roof Drain 200C4

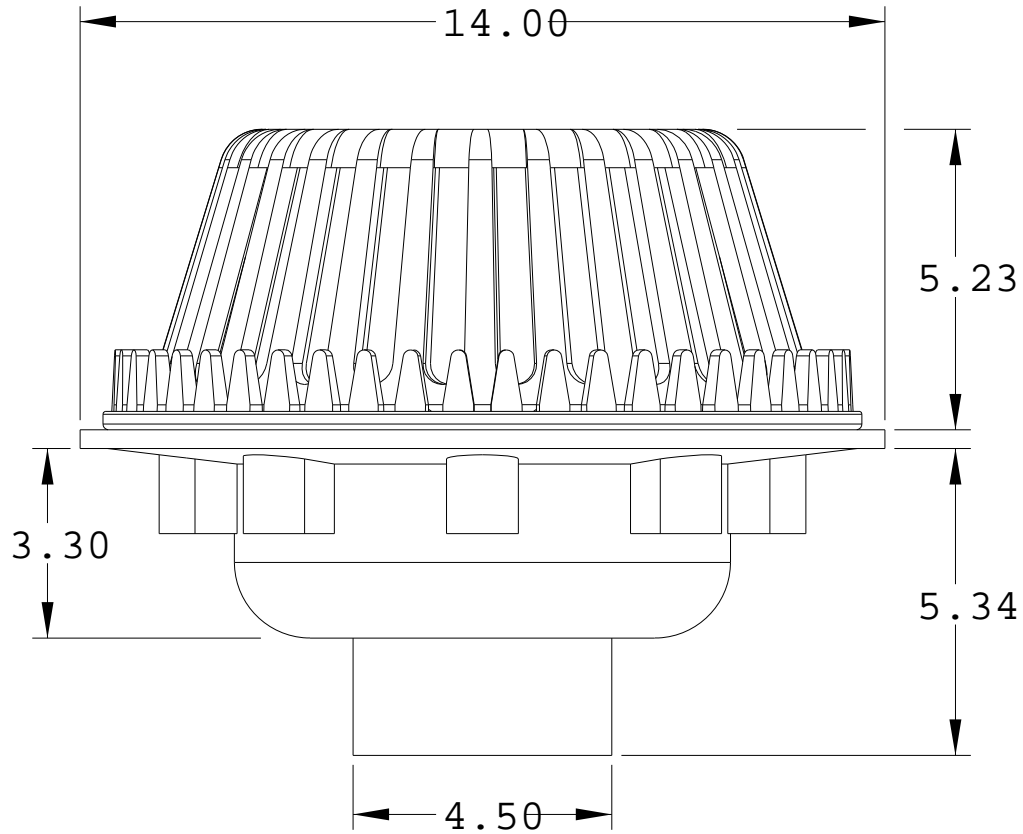

DC	Deck Clamp	FR	Finishing Ring
DEX-2	2" Ring Extension	IG	IRMA Roof Guard
DEX-4	4" Ring Extension	SP	Sump Drain Pan
DEX-6	6" Ring Extension	DMP	Deck Mounting Plate
DP	Drain Pan	CFW	Control Flow Weir

Specifications subject to change without notice

Froet Industries LLC - P.O. Box 787 - 1741 Industrial Drive - Sterling, Illinois 61081 - ph.815.626.7922 fx.815.626.0702
www.froetindustries.com

Froet Standard Roof Drain 200C5

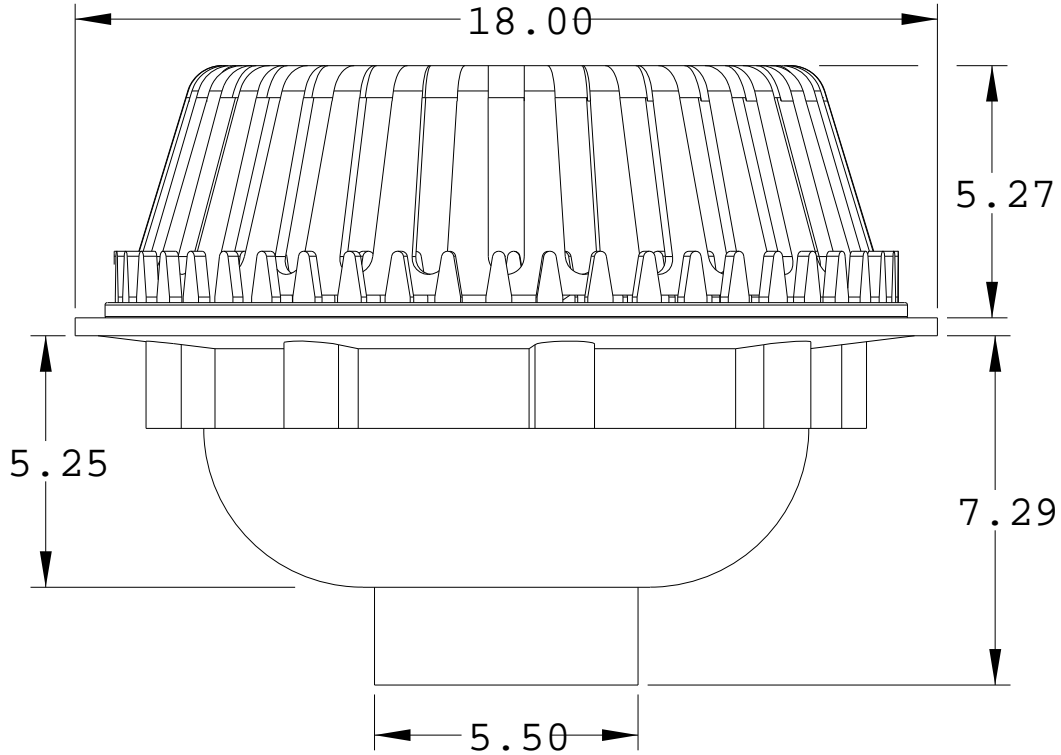

DC	Deck Clamp	FR	Finishing Ring
DEX-2	2" Ring Extension	IG	IRMA Roof Guard
DEX-4	4" Ring Extension	SP	Sump Drain Pan
DEX-6	6" Ring Extension	DMP	Deck Mounting Plate
DP	Drain Pan	CFW	Control Flow Weir

Specifications subject to change without notice

Froet Industries LLC - P.O. Box 787 -1741 Industrial Drive-Sterling, Illinois 61081 - ph.815.626.7922 fx.815.626.0702
www.froetindustries.com

Froet Standard Roof Drain 200C6

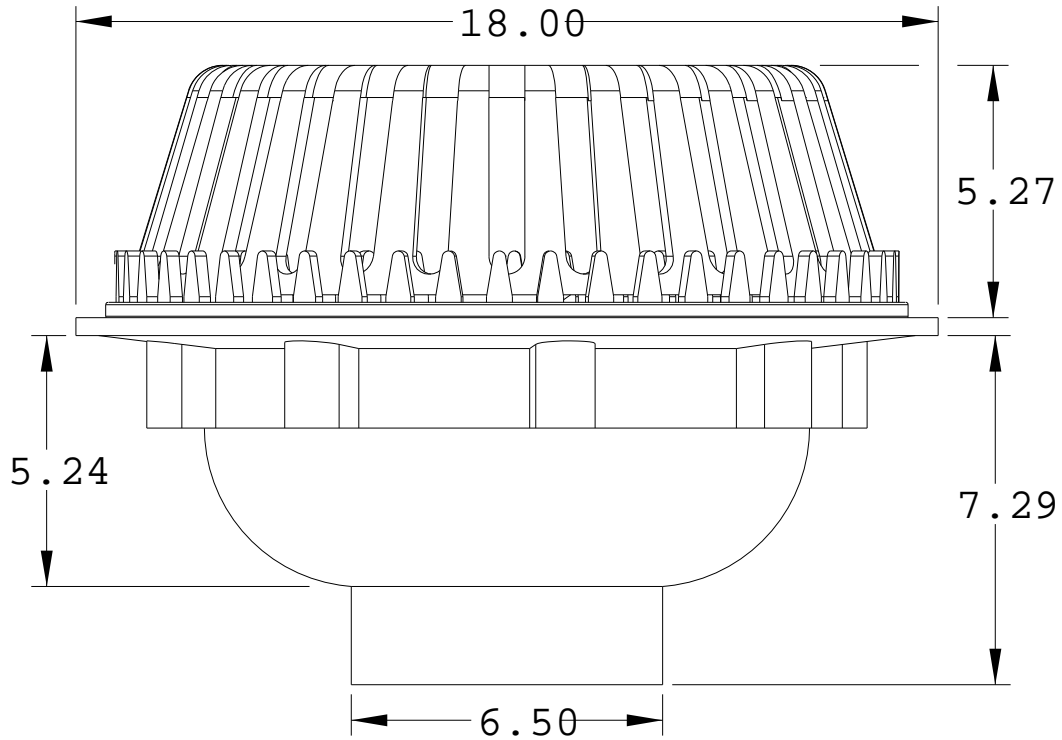

DC	Deck Clamp	FR	Finishing Ring
DEX-2	2" Ring Extension	IG	IRMA Roof Guard
DEX-4	4" Ring Extension	SP	Sump Drain Pan
DEX-6	6" Ring Extension	DMP	Deck Mounting Plate
DP	Drain Pan	CFW	Control Flow Weir

Specifications subject to change without notice

Froet Industries LLC - P.O. Box 787 -1741 Industrial Drive-Sterling, Illinois 61081 - ph.815.626.7922 fx.815.626.0702
www.froetindustries.com

Product Information and Design Criteria

Purpose of Roofs

The roof provides the building and its contents protection from the elements. It also provides drainage of storm water to the various drainage systems, (roof drains, scuppers and gutters) and directs it to the ground, retention ponds or storm sewer.

The roof structure transfers the combined weight of live and dead loads to the support members. (Live loads include snow, rain, wind, moving installation equipment, etc. Dead loads include HVAC units, roof drains, roofing system and the deck itself.)

Types of Roof Decks

- “ Steel roof decks
- “ Prestressed concrete roof decks
- “ Poured gypsum concrete roof decks
- “ Precast concrete panel roof decks
- “ Lightweight insulating concrete roof decks
- “ Reinforced concrete roof decks
- “ Cement-wood fiber panel decks
- “ Thermo-setting insulating fill roof decks
- “ Wood plank or plywood roof decks

Roof Types

- “ Single ply (EPDM, PVC, CSPE, TPO, etc.)
- “ Coal-tar pitch built-up
- “ Asphalt built-up
- “ Modified bitumen

Roofing System Design-The following information is provided for informational purposes only and not to be interpreted as a roofing specification. Modern roofing systems have different and unique criteria for their design.

1. The coal-tar and low melting point asphalt roofing systems need to be designed with low or no slope to prevent sagging of the roofing system and the bitumen flowing into the drainage system and causing a restriction.
2. With the introduction of white roofing systems and the Energy Star compliance increased slopes of roofing systems are desired to drain the water from the roofing system and not allow ponding water to stain the roofing system or promote mold growth.
3. A roof pitched properly to drain is usually designed for a loading of thirty pounds per square foot. A roof that backs up water both by design or by improper drain placement can be loaded in excess of this design factor and cause failure.
4. A roof must be designed in conjunction with the roof drainage equipment serving it. It is necessary to correlate the type roof specified with proper and adequately sized drains.
5. A dead level roof should be avoided unless its aspects are carefully detailed on plans and in specifications.
6. A roof drain selected for the installation must be designed to securely hold all plies regardless of thickness and should be recessed below the roof level in a properly designed sump.
7. Roof drains should be clearly detailed and located on plans to avoid ponding or pool formation. It is advisable to tie small outlet drains into large ones by running horizontal lines under the deck to the vertical leaders.

8. Specify overflow relief for parapet roofs. An overflow should be provided for each roof drain and it should be at the height stipulated by the local building code. This precaution is essential if the roof is used as a reservoir. In effect, such roofs become small lakes and are subject to wind action. Overflow relief omission or inadequacy can cause water build-up beyond load safety factor
9. Maintenance: The multipurpose roof or deck area so prevalent in modern buildings places a burden on the owner to maintain it properly. Such roofs and promenade areas are subject to build-up of debris at the roof drains causing improper drainage. Low maintenance costs can be achieved by carefully specifying the proper drain for each area, and by using an adequate number of drains to insure the removal of water.
10. Roof drains should be located as far from columns as possible so as the building settles with age the slope will increase.
11. Drains and stacks should be at least six foot from perimeter edges to allow for a proper sump and help protect maintenance workers from fall dangers.
12. All roof drains should be installed below finished roof level in a properly designed sump to promote good drainage.

How to Select a Roof Drain

- “ Local code requirements
- “ Type of roof construction
- “ Roof Pitch
- “ Volume of expected rainfall for the areas. (Table 1)
- “ Desired rate of drainage
- “ Roof load and safety overflow requirements
- “ Roof drain size

Sizing and Quantities

As a first step in the sizing procedure it will be necessary to determine the quantity and placement of the drains required for the roof. Even though there are a number of opinions regarding roof areas that can be effectively drained by one drain, it is recognized that for minimized ponding with adequate drainage, two roof drains are required for roof areas of 10,000 square feet or less, and at least one drain is required per 10,000 square feet of area for larger roofs. Individual judgment will be necessary when considering quantity and placement of drains on roofs where shape and size of sections may require departure from the 10,000 square feet per drain recommendation.

In the replacement of drains, uniform distribution is desirable for proper roof drainage. Also, careful consideration of roof structural members, dividers, expansion joints, and other projections including rooftop equipment is essential in planning the roof drainage system for adequate drainage of each area of the roof. Consultation with the architect and structural engineer regarding roof details is recommended.

Selecting drain size and quantity

Example:

1. Total roof area- 350' by 425' = 148750 sq. ft.
2. Rate of rainfall- Chicago IL = 3"
3. 4" leaders will be used
4. From Table 1- one 4" leader will handle 6130 sq. ft.
5. Quantity of roof leaders will be 25 (148750 sq. ft. divided by 6,130 sq. ft.)

Table 1

Leaders Pipe size (inches)	Roof Area Drained (sq-ft) verse Hourly Rainfall in Inches							
	1	2	3	4	5	6	7	8
2	2,880	1,440	960	720	575	480	410	360
3	8,880	4,400	2,930	2,200	1,760	1,470	1,260	1,100
4	18,400	9,200	6,130	4,600	3,680	3,070	2,630	2,300
5	34,600	17,300	11,530	8,650	6,920	5,765	4,945	4,325
6	54,000	27,000	18,000	13,500	10,800	9,000	7,715	6,750
8	116,000	58,000	38,680	29,000	23,300	19,315	15,570	14,500

Table 2

Allowable Flow in G.P.M.				
Pipe Size	Vertical Leader	Horizontal Storm Drain Slope Per foot		
		1/8"	1/4"	1/2"
2	30	12	17	24
3	90	36	51	72
4	192	78	111	157
5	348	142	201	284
6	566	231	327	462
8	1220	498	705	996
10	2200	902	1275	1804
12	-	1467	2067	2934
15	-	2666	3776	5332

Steps for Calculating Drainage Requirements using G.P.M.

- Use the following formula to Determine G.P.M.
 $G.P.M. = .0104 \times I \times A$
 G.P.M.= Gallons per minute
 I = Rainfall intensity- inches/hour
 A = Roof area- square feet
 .0104 = Conversion factor- G.P.M./sq. ft. for one (1) inch/hr. rainfall
- Example:
 a. 3" rainfall in./hr.
 b. 148,750 sq. ft. roof area
 c. $G.P.M. = .0104 \times 3 \times 148,750 \text{ sq. ft.} = 4641$
 G.P.M. (use 4650)
- Refer to table 2: a 4" leader will handle 192 G.P.M. 4650 divided by 192= 24.21 or 25 vertical leaders required.

Vertical walls

Vertical walls that project above the roof and permit storm water to drain on to the roof must be considered when planning for the roof drainage system. The accepted rule to follow is to add one half of the area of the vertical wall that diverts rainwater to the roof and add that amount to the total drainage area.

Please note:

The above information is based on the National Plumbing Code. Always consult your local code for specific design criteria. Leader size is to be determined by the design professional based on building plan design and job site conditions. The installation of multiple smaller drains as apposed to a couple larger drains increases the safety of the drainage system. Drains should be spaced for uniform drainage.

Disclaimer

Seller warrants that the Froet Drain® roof drain will be of the kind and quality described in the order and product literature and will be free of defects in workmanship or material. However, Seller does not warrant the application and use of the drain based upon the structural design and installation on a particular project. Careful consideration must be placed on the actual design of the structure when determining the burden of the overflow water.

Based on a storm of one hour duration and a 100-year return period. Source: National Weather Service, National Oceanic and Atmospheric Administration, Washington, DC.

ALABAMA

Birmingham 3.8
Huntsville 3.6
Mobile 4.6
Montgomery 4.2

ALASKA

Fairbanks 1.0

Juneau 0.6

ARIZONA

Flagstaff 2.4
Nogales 3.1
Phoenix 2.5
Yuma 1.6

ARKANSAS

Fort Smith 3.6
Little Rock 3.7
Texarkana 3.8

CALIFORNIA

Barstow 1.4
Crescent City 1.5
Fresno 1.1
Los Angeles 2.1
Needles 1.6
Sacramento 1.6
San Diego 1.3
San Francisco 1.5

COLORADO

Denver 2.4
Durango 1.8
Grand Junction 1.7
Pueblo 2.5

CONNECTICUT

Hartford 2.7
New Haven 2.8

DELAWARE

Georgetown 3.0
Wilmington 3.1

DISTRICT OF

COLUMBIA

Washington 3.2

FLORIDA

Jacksonville 4.3
Key West 4.3
Miami 4.7
Pensacola 4.6
Tampa 4.5

GEORGIA

Atlanta 3.7
Macon 3.9
Savannah 4.3
Thomasville 4.3

HAWAII

Hilo 6.2
Honolulu 3.0

IDAHO

Boise 0.9
Pocatello 1.2

ILLINOIS

Cairo 3.3
Chicago 3.0
Peoria 3.1
Springfield 3.3

INDIANA

Evansville 3.2
Fort Wayne 2.9
Indianapolis 3.1
South Bend 3.0
Terre Haute 3.2

IOWA

Burlington 3.3
Davenport 3.3
Des Moines 3.5
Dubuque 3.3
Sioux City 3.6

KANSAS

Atwood 3.3
Dodge City 3.4
Topeka 3.7
Wichita 3.7

KENTUCKY

Ashland 3.0
Bowling Green 3.2
Lexington 3.1
Louisville 3.2
Middlesboro 2.8
Paducah 3.3

LOUISIANA

Baton Rouge 4.8
Lake Charles 4.7
New Orleans 4.8
Shreveport 3.9

MAINE

Bangor 2.2
Caribou 2.0
Portland 2.4

MARYLAND

Baltimore 3.2
Hagerstown 2.8
Salisbury 3.1

MASSACHUSETTS

Boston 2.5
New Bedford 2.6
Pittsfield 2.8
Springfield 2.7

MICHIGAN

Alpena 2.5
Detroit 2.8
Escanaba 2.4
Grand Rapids 2.8
Lansing 2.8
Marquette 2.4
Sault Ste. Marie 2.2

MINNESOTA

Duluth 2.6
Grand Forks 2.5
Minneapolis 3.0
Worthington 3.4

MISSISSIPPI

Biloxi 4.7
Columbus 3.9
Jackson 4.0
Natchez 4.4

MISSOURI

Columbia 3.3
Kansas City 3.6
St. Louis 3.3
Springfield 3.4

MONTANA

Billings 1.9
Havre 1.6
Helena 1.5
Missoula 1.3

NEBRASKA

Grand Island 3.5
Omaha 3.8
Sidney 3.2

Valentine 3.2

NEVADA

Carson City 1.1
Elko 1.0
Las Vegas 1.5

NEW HAMPSHIRE

Berlin 2.5
Claremont 2.5
Portsmouth 2.4

NEW JERSEY

Atlantic City 3.0
Newark 3.1
Trenton 3.1

NEW MEXICO

Albuquerque 2.0
Hobbs 3.0
Las Cruces 2.0
Santa Fe 2.0

NEW YORK

Albany 2.6
Binghamton 2.3
Buffalo 2.3
New York 3.0
Syracuse 2.3
Watertown 2.2

NORTH CAROLINA

Asheville 4.1
Charlotte 3.7
Greensboro 3.5
Raleigh 3.7
Wilmington 4.2

NORTH DAKOTA

Bismarck 2.8
Fargo 3.2
Grand Forks 3.0
Williston 2.6

OHIO

Cincinnati 3.0
Cleveland 2.8
Columbus 2.8
Toledo 2.8
Youngstown 2.7
Zanesville 2.8

OKLAHOMA

Oklahoma City 3.8
Tulsa 3.8

OREGON

Medford 1.4
Pendleton 1.0
Portland 1.3

PENNSYLVANIA

Erie 2.6
Harrisburg 2.8
Philadelphia 3.1
Pittsburgh 2.6
Scranton 2.7
Williamsport 2.6

RHODE ISLAND

Providence 2.6

SOUTH CAROLINA

Charleston 4.3
Columbia 4.0
Greenville 4.2

SOUTH DAKOTA

Aberdeen 3.3
Pierre 3.2
Rapid-City 2.9
Sioux Falls 3.6

TENNESSEE

Chattanooga 3.5
Knoxville 3.2
Memphis 3.7
Nashville 3.3

TEXAS

Abilene 3.6
Amarillo 3.5
Brownsville 4.5
Corpus Christi 4.5
Dallas 4.0
El Paso 2.4
Houston 4.6
Lubbock 3.3
Odessa 3.2
San Antonio 4.2
Tyler 3.9

UTAH

Cedar City 1.6
Salt Lake City 1.3

VERMONT

Brattleboro 2.5
Burlington 2.2

VIRGINIA

Bristol 2.7
Charlottesville 2.9
Norfolk 3.4
Richmond 3.3
Roanoke 3.2

WASHINGTON

Bellingham 1.1
Seattle 1.1
Spokane 1.0
Yakima 1.0

WEST VIRGINIA

Charleston 2.8
Elkins 2.7
Parkersburg 2.8

WISCONSIN

Ashland 2.5
Eau Claire 3.0
Green Bay 2.5
La Crosse 3.1
Madison 3.0
Milwaukee 3.0

WYOMING

Casper 1.9
Cheyenne 2.2
Rock Springs 1.3
Sheridan 1.7
Yellowstone Park 1.

GENERAL TERMS AND CONDITIONS

FREIGHT ALLOWANCE: F.O.B. Sterling, Illinois, with full motor freight allowed on shipments of \$45,000.00 net amount or more, within the Continental U.S.A., except Alaska, Hawaii, and Puerto Rico. We reserve the right to select the carrier and to route the shipment at our discretion. There is no allowance for Parcel Post, United Parcel Service or shipments by air.

TERMS: 30 days net unless prior approved special terms. Invoices not paid 30 days after invoice date will be subject to 1-1/2% service charge applied monthly. Minimum invoice: \$25.00 net. Confirmed irrevocable letter of credit or cash in advance of shipment is required for accounts without an established line of credit.

DEBTS, CREDITS, DEDUCTIONS, RETURNS: All items in these categories must first be referred to Credit Department for APPROVAL and prompt handling. All items in these categories must be accompanied with a photocopy of the invoice on which the material was charged.

QUOTATION TERMS: List price and discount are protected for 45 days from **Bid Due Date**. If an order is received within this period, the material must be released within 90 days from date of order; otherwise, prices will be those in effect at the time of shipment.

ORDER ACCEPTANCE: All catalogs, price lists, literature or other material describing our products are not to be construed as offers to sell same. Orders are subject to acceptance by our office in Sterling, Illinois. Your order, when shipped, shall be the complete contract, subject to and incorporating therein the terms and conditions herein contained, and any inconsistent provisions contained in your order shall not apply. Prices and discounts contained in any of our catalogs, price lists or other literature are subject to change without notice.

CANCELLATION: Orders are not subject to cancellation without our written consent. If an order is canceled, the Buyer shall pay all costs incurred with filling the order. Any charges incurred because of cancellation or change of special materials made to order must be paid for by the Buyer. Any items not cataloged by us and made on a special order remain the property of the Buyer and must be paid for.

GUARANTEE/WARRANTY: All Froet Industries LLC products are guaranteed against defective materials and workmanship for a period of one year from the date of purchase. We will replace, free of charge, any product proven defective that has been properly installed, properly maintained, and used in accordance with recommended instructions. We shall not be responsible for any labor charges or any loss, injury or damages whatsoever, including incidental or consequential damages. The warranty is limited solely to the replacement of the defective goods. **This warranty is in lieu of all other warranties, express, implied in fact or implied by law, including any warranty of merchantability or fitness for a particular purpose, which are hereby expressly disclaimed.**

DELAYS: Froet Industries LLC will not assume any liability for delays or defaults occasioned by strikes, fires, or acts of governmental authorities, failure to obtain materials, or by cause unavoidable beyond its control.

RETURNED GOODS: Material may be returned subject to the following conditions:

1. Must first be referred to Froet Industries LLC for inspection, approval, and prompt handling;
2. Minimum value of \$100.00 net;
3. Credit for parts given only if purchased as parts;
4. Wholesaler must identify original shipment of material by invoice number and invoice date;
5. Prior written permission;
6. 25% restocking fee;
7. Any charges necessary to put the material into saleable condition shall be Buyer's responsibility;

8. Credit will be issued to apply only against future purchases;
9. Outgoing freight will be deducted from the credit;
10. Material must be returned freight prepaid.

ILLUSTRATIONS AND DESCRIPTIONS: All illustrations, submittals, and accompanying descriptions describe standard features of each product and do not necessarily show or describe the variations available. All designs are subject to change without notice, and unless specifically stated on the order, material will be furnished of design in effect at the time the order is filled. All weights are approximate.

RISKS: Our responsibility ceases after the product has been delivered to the carrier in good order. It is the responsibility of the Buyer to inspect each shipment carefully and file a claim with the carrier for any damage or shortage. Content shortages must be reported within 15 days after the receipt of material. Any claim after this time will be disallowed.

SHIPPING DATES: Promise of shipping dates are estimates, but not guaranteed.